

CUTTERHEAD ALIGNMENT

Model 40255/40255H

www.steelcitytoolworks.com

VER. 02.6.14

Cutterhead Alignment

The most critical adjustments made on your new planer are dependent on the cutterhead body being parallel to the table. Because of this alignment, checking the table is the first step to establishing an accurate planer.

There are two dimensions you should be concerned about when checking/aligning the table—the cutterhead casting should be parallel to the table from front-to-back, and the cutterhead should be parallel with the table from side-to-side.

The cutterhead casting and the cutterhead body has been pre-set at the factory, but it is a good idea to check any machine thoroughly before use.

To check the cutterhead-to-table alignment, do these steps:

1. **UNPLUG THE PLANER!**
2. If you have not already done so, loosen the setscrews where the table bed rollers mount to the planer body at either end of both rollers. See Figure 12.
3. Use a wrench to lower the rollers on their eccentric shafts. Leave the table rollers in the retracted position until instructed to reset the knife height at the end of this section.
4. Make the gauge shown in Figure 13 out of a block of wood.
5. Place the block on one end of the table, directly under the cutterhead casting.
6. Lower the cutterhead casting so the block only touches the cutterhead casting (keep knives rotated out of the way for this step). See Figure 14.
7. Without moving the cutterhead casting, slide the block of wood to the other end of the cutterhead casting. If the block of wood will not fit, or if the block is below the casting, measure this gap with a feeler gauge. If the difference is more than 0.002", then the cutterhead casting needs to be adjusted from left to right.

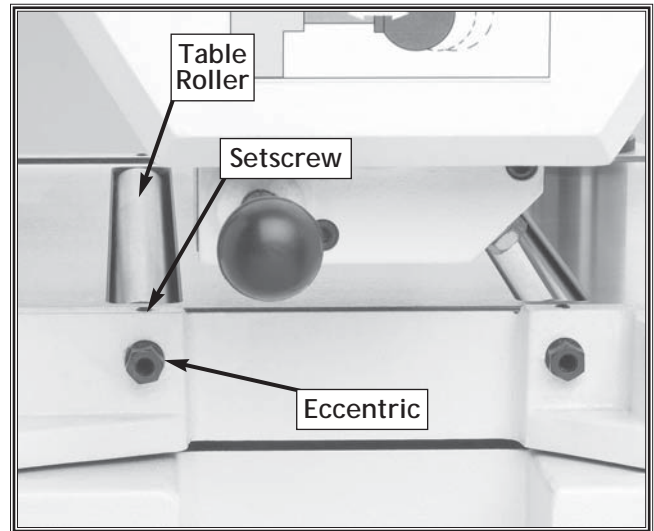

Figure 12. Table bed roller adjustment.

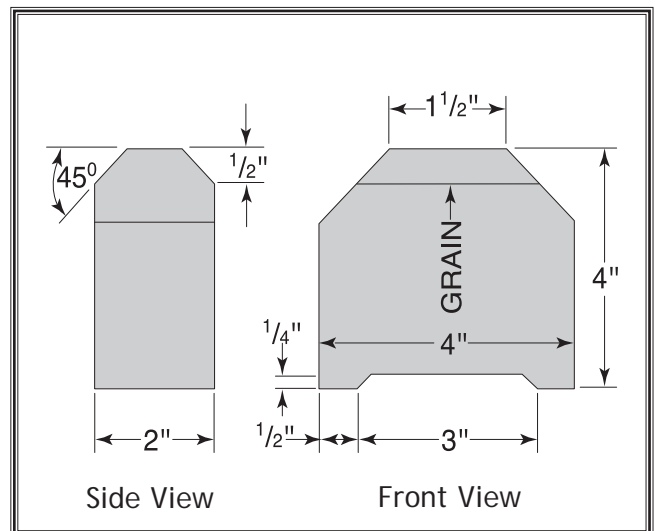

Figure 13. Gauge block.



Figure 14. Checking cutterhead alignment.

8. Place the block under the front of the head casting to either side of the depth stop.
9. Lower the cutterhead casting so the block barely touches the casting.
10. Remove the block and place it between the middle-rear of the cutterhead casting and the table. If there is a gap or it will not fit under the head casting, measure the difference with a feeler gauge. If this measurement is more than 0.002", then the table needs to be adjusted from front to back.
11. There are two methods to adjust the table on your planer. The first is for adjustments smaller than 0.016" and the second is for adjustments larger than 0.016".

To adjust the cutterhead casting less than 0.016", do these steps:

NOTE : This adjustment may require some trial and error and two people. One person holds the head casting in position with the two-by-four, and the other tightens the casting mounting screws shown in Figure 15.

1. Loosen the cutterhead casting mounting screws and lift/lower the casting with a long two-by-four until the table and the casting are parallel with each other.
2. Adjust each column on both sides until the cutterhead casting is properly set. While adjusting the columns, tighten each screw after each step to ensure accurate results.

To adjust the cutterhead casting more than 0.016", do these steps:

NOTE : The underside of the table has five sprockets and a chain. The four corner sprockets control cutterhead casting height, and the fifth sprocket (idler sprocket) controls chain tension. See Figure 16.

1. Loosen the two bolts on the idler sprocket bracket (as shown in Figure 16) to loosen the chain so that each sprocket can be rotated on its own. See Figure 17.

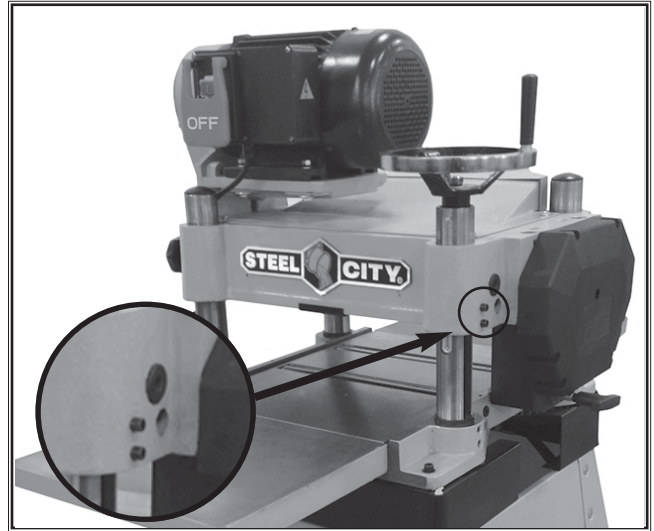

Figure 15. Cutterhead casting mounting screws.

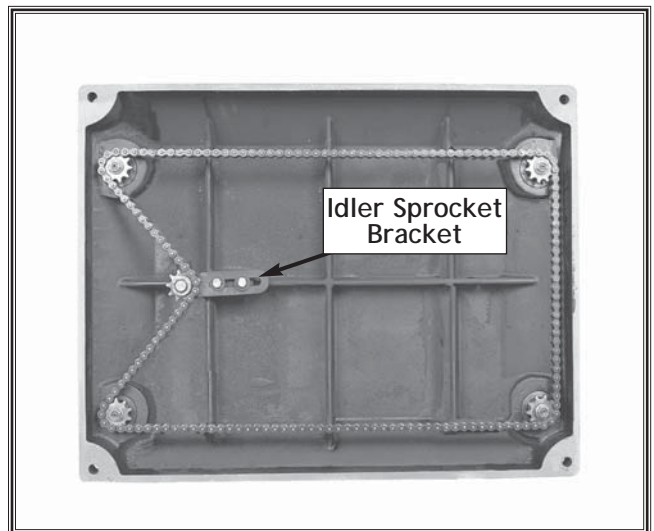

Figure 16. Underside of planer table.

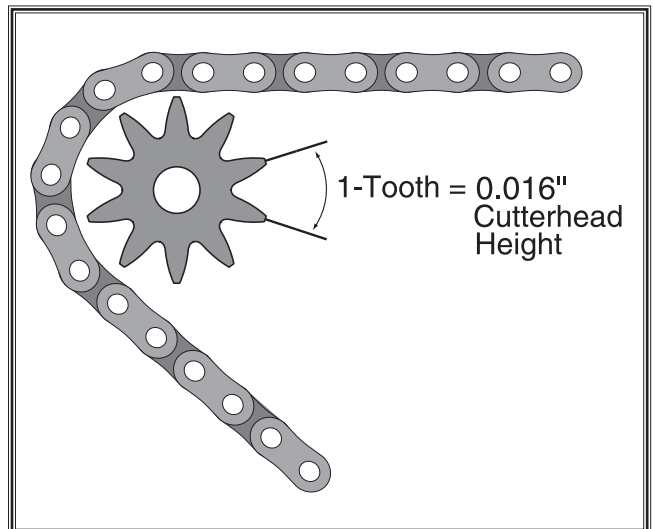

Figure 17. Sprocket tooth-to-height ratio.

2. Hold the chain away from the sprocket while you turn the sprocket. Make sure, as you adjust each sprocket, that you count the number of teeth that pass a fixed point.

NOTE: As viewed from the underside of planer, moving the sprockets clockwise lowers the cutterhead casting and moving counter-clockwise raises the casting. Each tooth on the corner sprockets equals 0.016" of vertical movement when the sprockets are turned. See **Figure 17**.

3. After you have the cutterhead casting adjusted to within 0.016" from front-to-back and from side-to-side, tighten the chain so all of the chain slack is removed.

4. Loosen the cutterhead casting mounting screws and use a two-by-four to pry and lift/lower the cutterhead casting until the casting and table are parallel with each other.

NOTE : This adjustment may require some trial and error and two people. One person holds the head casting in position with the two-by-four, and the other tightens the casting mounting screws shown in **Figure 15**.

5. Adjust each column on both sides until the cutterhead casting is properly set. While adjusting the columns, tighten each screw after each step to ensure accurate results.

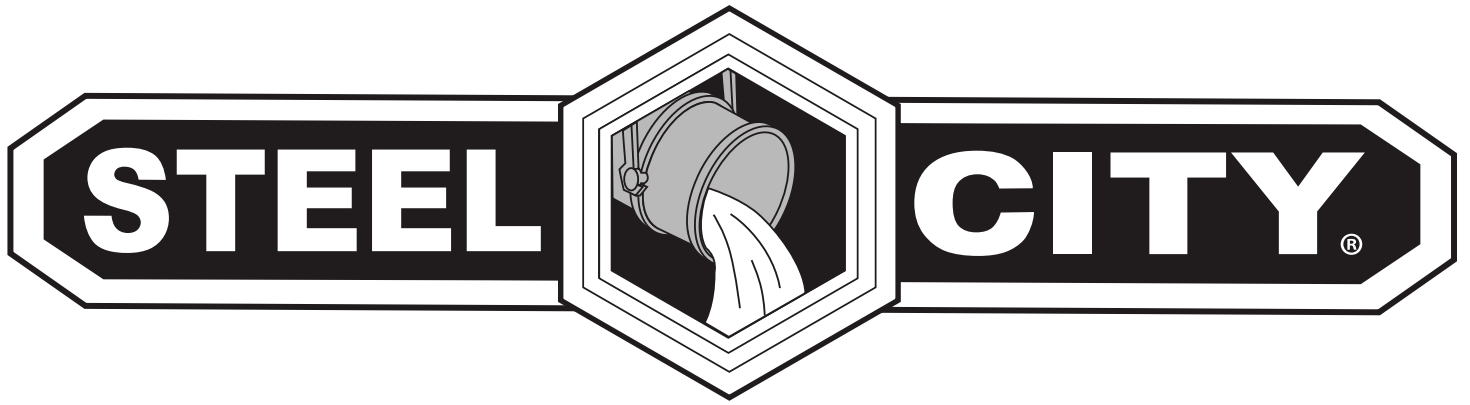

STEEL CITY TOOL WORKS

www.steelcitytoolworks.com

1-877-SC4-TOOL
(1-877-724-8665)

NOTES

www.steelcitytoolworks.com

Steel City Tool Works, LLC Bolingbrook, IL. USA 60440

Tech Service: 1.877.724.8665