



User Manual

Read and understand this manual before using machine.

15-30 WIDE BELT SANDER



Model No.
55225



STEEL CITY TOOL WORKS
VER. 7.07

Manual Part No. OR74178



THANK YOU for purchasing your new Steel City Wide Belt Sander. This wide belt sander has been designed, tested, and inspected with you, the customer, in mind. When properly assembled, used and maintained, your wide belt sander will provide you with years of trouble free service, which is why it is backed by one of the longest machinery warranties in the business.

This wide belt sander is just one of many products in the Steel City's family of woodworking machinery and is proof of our commitment to total customer satisfaction.

At Steel City we continue to strive for excellence each and every day and value the opinion of you, our customer. For comments about your wide belt sander or Steel City Tool Works, please visit our web site at www.steelcitytoolworks.com .

TABLE OF CONTENTS

INTRODUCTION

SECTION 1	Warranty	4
SECTION 2	Product Specifications	7
SECTION 3	Accessories and Attachments	7
SECTION 4	Feature Identification	8
SECTION 5	General Safety	9
SECTION 6	Product Safety	11
SECTION 7	Electrical Requirements	12
SECTION 8	Grounding Instructions.....	13
SECTION 9	Unpacking & Inventory.....	14
SECTION 10	Assembly	16
SECTION 11	Adjustments	18
SECTION 12	Operations	22
SECTION 13	Maintenance	23
SECTION 14	Troubleshooting	24
SECTION 15	Parts List.....	26

INTRODUCTION

This user manual is intended for use by anyone working with this machine. It should be kept available for immediate reference so that all operations can be performed with maximum efficiency and safety. Do not attempt to perform maintenance or operate this machine until you have read and understand the information contained in this manual.

The drawings, illustrations, photographs, and specifications in this user manual represent your machine at time of print. However, changes may be made to your machine or this manual at any time with no obligation to Steel City Tool Works.

WARRANTY

STEEL CITY TOOL WORKS 5 YEAR LIMITED WARRANTY

Steel City Tool Works, LLC (“SCTW”) warrants all “STEEL CITY TOOL WORKS” machinery to be free of defects in workmanship and materials for a period of 5 years from the date of the original retail purchase by the original owner. SCTW will repair or replace, at its expense and at its option, any SCTW machine, machine part, or machine accessory which in normal use has proven to be defective, provided that the customer returns the product, shipping prepaid, to an authorized service center with proof of purchase and provides SCTW with a reasonable opportunity to verify the alleged defect by inspection. This warranty does not apply to defects due directly or indirectly to misuse, abuse, negligence, accidents, or lack of maintenance, or to repairs or alterations made or specifically authorized by anyone other than SCTW. Normal wear components are also excluded under this coverage. Every effort has been made to ensure that all SCTW machinery meets the highest quality and durability standards. We reserve the right to change specifications at any time due to our commitment to continuous improvement of the quality of our products.

EXCEPT AS SET FORTH ABOVE, SCTW MAKES NO EXPRESS OR IMPLIED REPRESENTATIONS OR WARRANTIES WITH RESPECT TO ITS MACHINERY, OR ITS CONDITION, MERCHANTABILITY, OR FITNESS FOR ANY PARTICULAR PURPOSE OR USE. SCTW FURNISHES THE ABOVE WARRANTIES IN LIEU OF ALL OTHER WARRANTIES, EXPRESS OR IMPLIED, INCLUDING THE WARRANTIES OF MERCHANTABILITY AND FITNESS FOR A PARTICULAR PURPOSE, WHICH ARE HEREBY SPECIFICALLY DISCLAIMED.

SCTW SHALL NOT BE LIABLE FOR ANY (A) SPECIAL, INDIRECT, INCIDENTAL, PUNITIVE OR CONSEQUENTIAL DAMAGES, INCLUDING WITHOUT LIMITATION LOSS OF PROFITS, ARISING FROM OR RELATED TO THIS WARRANTY, THE BREACH OF ANY AGREEMENT OR WARRANTY, OR THE OPERATION OR USE OF ITS MACHINERY, INCLUDING WITHOUT LIMITATION DAMAGES ARISING FROM DAMAGE TO FIXTURES, TOOLS, EQUIPMENT, PARTS OR MATERIALS, DIRECT OR INDIRECT LOSS CAUSED BY ANY OTHER PARTY, LOSS OF REVENUE OR PROFITS, FINANCING OR INTEREST CHARGES, AND CLAIMS BY ANY THIRD PERSON, WHETHER OR NOT NOTICE OF SUCH POSSIBLE DAMAGES HAS BEEN GIVEN TO SCTW; (B) DAMAGES OF ANY KIND FOR ANY DELAY BY OR FAILURE OF SCTW TO PERFORM ITS OBLIGATIONS UNDER THIS AGREEMENT; OR (C) CLAIMS MADE A SUBJECT OF A LEGAL PROCEEDING AGAINST SCTW MORE THAN ONE (1) YEAR AFTER SUCH CAUSE OF ACTION FIRST AROSE.

The validity, construction and performance of this Warranty and any sale of machinery by SCTW shall be governed by the laws of the Commonwealth of Pennsylvania, without regard to conflicts of laws provisions of any jurisdiction. Any action related in any way to any alleged or actual offer, acceptance or sale by SCTW, or any claim related to the performance of any agreement including without limitation this Warranty, shall take place in the federal or state courts in Allegheny County, Pennsylvania.

STEEL CITY TOOL WORKS

WARRANTY CARD

Name _____
 Street _____
 Apt. No. _____
 City _____ State _____ Zip _____
 Phone Number _____
 E-Mail _____

Product Description: _____
 Model No.: _____
 Serial No. _____

The following information is given on a voluntary basis and is strictly confidential.

1. Where did you purchase your STEEL CITY machine?
 Store: _____
 City: _____

2. How did you first learn of Steel City Tool Works?
 Advertisement Mail Order Catalog
 Web Site Friend
 Local Store Other _____

3. Which of the following magazines do you subscribe to?
 American Woodworker American How-To
 Cabinetmaker Family Handyman
 Fine Homebuilding Fine Woodworking
 Journal of Light Construction Old House Journal
 Popular Mechanics Popular Science
 Popular Woodworking Today's Homeowner
 WOOD Woodcraft
 WOODEN Boat Woodshop News
 Woodsmith Woodwork
 Woodworker Woodworker's Journal
 Workbench Other _____

4. Which of the following woodworking / remodeling shows do you watch?
 Backyard America The American Woodworker
 Home Time The New Yankee Workshop
 This Old House Woodwright's Shop
 Other _____

5. What is your annual household income?
 \$20,000 to \$29,999 \$30,000 to \$39,999
 \$40,000 to \$49,999 \$50,000 to \$59,999
 \$60,000 to \$69,999 70,000 to \$79,999
 \$80,000 to \$89,999 \$90,000 +

6. What is your age group?
 20 to 29 years 30 to 39 years
 40 to 49 years 50 to 59 years
 60 to 69 years 70 + years

7. How long have you been a woodworker?
 0 to 2 years 2 to 8 years
 8 to 20 years over 20 years

8. How would you rank your woodworking skills?
 Simple Intermediate
 Advance Master Craftsman

9. How many Steel City machines do you own? _____

10. What stationary woodworking tools do you own?
Check all that apply.
 Air Compressor Band Saw
 Drill Press Drum Sander
 Dust Collection Horizontal Boring Machine
 Jointer Lathe
 Mortiser Panel Saw
 Planer Power Feeder
 Radial Arm Saw Shaper
 Spindle Sander Table Saw
 Vacuum Veneer Press Wide Belt Sander
 Other _____

11. Which benchtop tools do you own? *Check all that apply.*
 Belt Sander Belt / Disc Sander
 Drill Press Band Saw
 Grinder Mini Jointer
 Mini Lathe Scroll Saw
 Spindle / Belt Sander Other _____

12. Which portable / hand held power tools do you own?
Check all that apply.
 Belt Sander Biscuit Jointer
 Dust Collector Circular Saw
 Detail Sander Drill / Driver
 Miter Saw Orbital Sander
 Palm Sander Portable Thickness Planer
 Saber Saw Reciprocating Saw
 Router Other _____

13. What machines / accessories would you like to see added to the STEEL CITY line?

14. What new accessories would you like to see added?

15. Do you think your purchase represents good value?
 Yes No

16. Would you recommend STEEL CITY products to a friend?
 Yes No

17. Comments:

CUT HERE

FOLD ON DOTTED LINE

PLACE
STAMP
HERE

Steel City Tool Works
P.O. Box 10529
Murfreesboro, TN 37129

FOLD ON DOTTED LINE

PRODUCT SPECIFICATIONS

DRUM MOTOR SPECIFICATIONS

Type	Induction
Continuous Duty Horsepower	3HP
Amps	11 Amps
Voltage	230
Phase	Single
Hertz	60
RPM	1725

PRODUCT DIMENSIONS

Footprint	30-1/4" x 19-1/4"
Depth	37" (with extension tables 40-1/2")
Width	27" (with extension tables 41")
Height	62"
Weight	388 lbs.

BELT FEED MOTOR SPECIFICATIONS

Type	Universal
Horsepower	1/6 HP

SHIPPING DIMENSIONS

Carton Type	Wooden Crate
Depth	39"
Width	30-1/4"
Height	65-1/2"
Gross Weight	518 lbs.

PRODUCT SPECIFICATIONS

Maximum Sanding Width	15" (one pass) 30" (two passes)
Maximum Thickness of Workpiece	5"
Minimum Thickness of Workpiece	1/4"
Feed rate	Variable (6-10 FPM)
Drum Size (diameter x width)	3-1/4" x 16"
Dust Port	4"

ACCESSORIES AND ATTACHMENTS

There are a variety of accessories available for your Steel City Product. For more information on any accessories associated with this and other machines, please contact your nearest Steel City distributor, or visit our website at: www.steelcitytoolworks.com.

FEATURE IDENTIFICATION

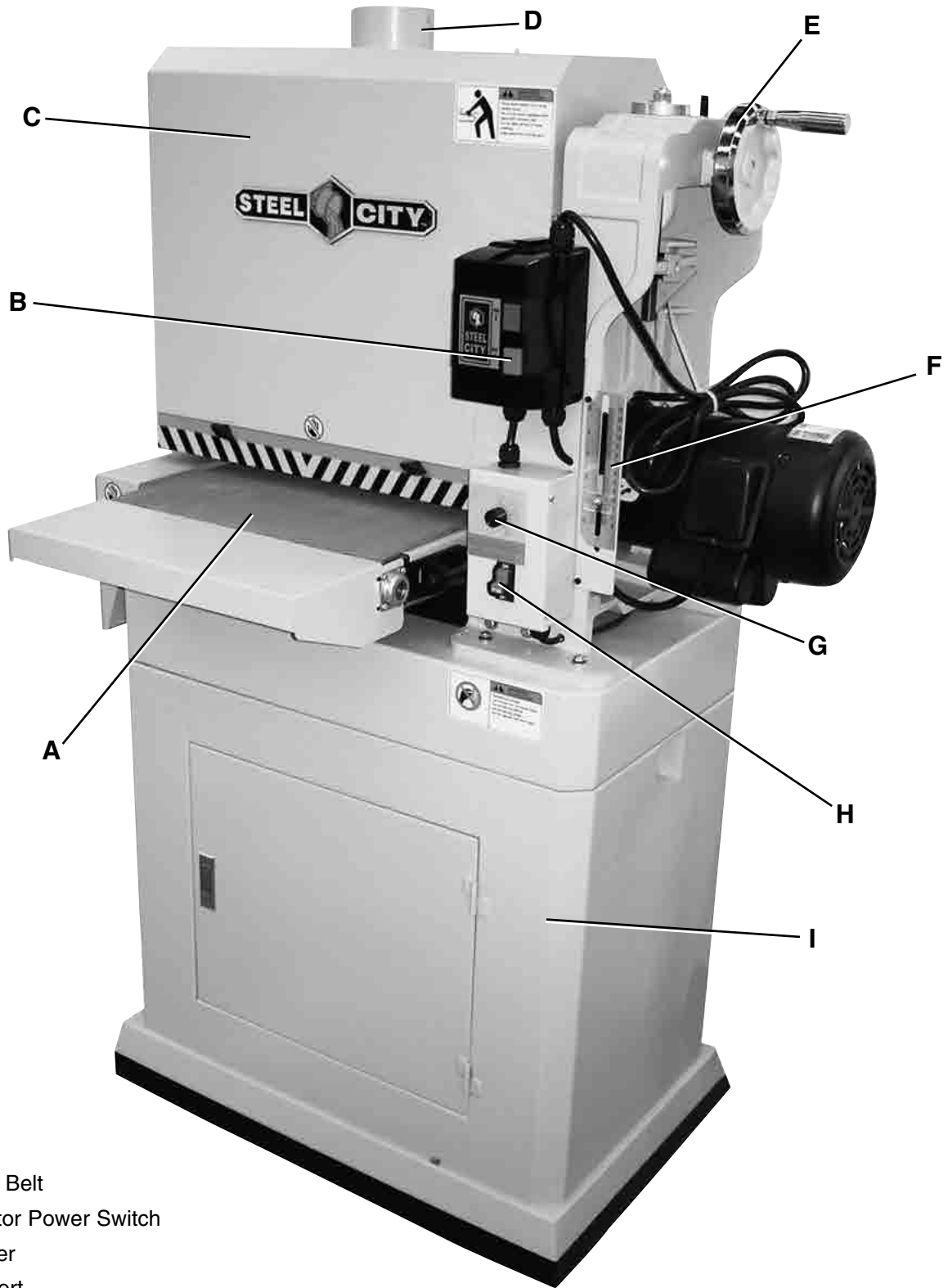

- A. Conveyor Belt
- B. Drum Motor Power Switch
- C. Dust Cover
- D. 4" Dust Port
- E. Sanding Drum Raise / Lower Handwheel
- F. Depth Scale
- G. Conveyor Belt Variable Speed Control
- H. Conveyor Belt Power Switch
- I. Base

GENERAL SAFETY

⚠ WARNING

TO AVOID serious injury and damage to the machine, read and follow all Safety and Operating Instructions before assembling and operating this machine.

This manual is not totally comprehensive. It does not and can not convey every possible safety and operational problem which may arise while using this machine. The manual will cover many of the basic and specific safety procedures needed in an industrial environment.

All federal and state laws and any regulations having jurisdiction covering the safety requirements for use of this machine take precedence over the statements in this manual. Users of this machine must adhere to all such regulations.

Below is a list of symbols that are used to attract your attention to possible dangerous conditions.



This is the international safety alert symbol. It is used to alert you to potential personal injury hazards. Obey all safety messages that follow this symbol to avoid possible injury or death.

⚠ DANGER

Indicates an imminently hazardous situation which, if not avoided, **WILL** result in death or serious injury.

⚠ WARNING

Indicates a potentially hazardous situation which, if not avoided, **COULD** result in death or serious injury.

⚠ CAUTION

Indicates a potentially hazardous situation, if not avoided, **MAY** result in minor or moderate injury. It may also be used to alert against unsafe practices.

CAUTION

CAUTION used without the safety alert symbol indicates a potentially hazardous situation which, if not avoided, may result in property damage.

NOTICE

This symbol is used to alert the user to useful information about proper operation of the machine.

⚠ WARNING

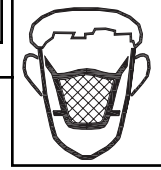

Exposure to the dust created by power sanding, sawing, grinding, drilling and other construction activities may cause serious and permanent respiratory or other injury, including silicosis (a serious lung disease), cancer, and death. Avoid breathing the dust, and avoid prolonged contact with dust. The dust may contain chemicals known to the State of California to cause cancer, birth defects or other reproductive harm.

Some examples of these chemicals are:

- Lead from lead-based paints.
- Crystalline silica from bricks, cement and other masonry products.
- Arsenic and chromium from chemically-treated lumber.

Always operate tool in well ventilated area and provide for proper dust removal. Use a dust collection system along with an air filtration system whenever possible. Always use properly fitting NIOSH/OSHA approved respiratory protection appropriate for the dust exposure, and wash exposed areas with soap and water.

1. To avoid serious injury and damage to the machine, read the entire User Manual before assembly and operation of this machine.

⚠ WARNING

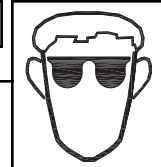

2. **ALWAYS** wear eye protection. Any machine can throw debris into the eyes during operations, which could cause severe and permanent eye damage. Everyday eyeglasses are **NOT** safety glasses. **ALWAYS** wear Safety Goggles (that comply with ANSI standard Z87.1) when operating power tools.

▲ WARNING

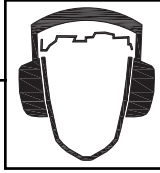

3. **ALWAYS** wear hearing protection. Plain cotton is not an acceptable protective device. Hearing equipment should comply with ANSI S3.19 Standards.

▲ WARNING

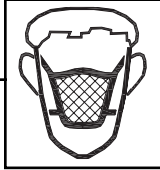

4. **ALWAYS** wear a NIOSH/OSHA approved dust mask to prevent inhaling dangerous dust or airborne particles.

5. **ALWAYS** keep the work area clean, well lit, and organized. **DO NOT** work in an area that has slippery floor surfaces from debris, grease, and wax.
6. **ALWAYS** unplug the machine from the electrical receptacle before making adjustments, changing parts or performing any maintenance.
7. **AVOID ACCIDENTAL STARTING.** Make sure that the power switch is in the "OFF" position before plugging in the power cord to the electrical receptacle.

▲ WARNING

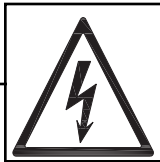

8. **AVOID** a dangerous working environment. **DO NOT** use electrical tools in a damp environment or expose them to rain or moisture.

▲ WARNING



9. **CHILDPROOF THE WORKSHOP AREA** by removing switch keys, unplugging tools from the electrical receptacles, and using padlocks.

10. **DO NOT** use electrical tools in the presence of flammable liquids or gasses.

11. **DO NOT FORCE** the machine to perform an operation for which it was not designed. It will do a safer and higher quality job by only performing operations for which the machine was intended.
12. **DO NOT** stand on a machine. Serious injury could result if it tips over or you accidentally contact any moving part.
13. **DO NOT** store anything above or near the machine.
14. **DO NOT** operate any machine or tool if under the influence of drugs, alcohol, or medication.
15. **EACH AND EVERY** time, check for damaged parts prior to using any machine. Carefully check all guards to see that they operate properly, are not damaged, and perform their intended functions. Check for alignment, binding or breakage of all moving parts. Any guard or other part that is damaged should be immediately repaired or replaced.
16. Ground all machines. If any machine is supplied with a 3-prong plug, it must be plugged into a 3-contact electrical receptacle. The third prong is used to ground the tool and provide protection against accidental electric shock. **DO NOT** remove the third prong.
17. Keep visitors and children away from any machine. **DO NOT** permit people to be in the immediate work area, especially when the machine is operating.
18. **KEEP** protective guards in place and in working order.
19. **MAINTAIN** your balance. **DO NOT** extend yourself over the tool. Wear oil resistant rubber soled shoes. Keep floor clear of debris, grease, and wax.
20. **MAINTAIN** all machines with care. **ALWAYS KEEP** machine clean and in good working order. **KEEP** all blades and tool bits sharp.
21. **NEVER** leave a machine running, unattended. Turn the power switch to the OFF position. **DO NOT** leave the machine until it has come to a complete stop.
22. **REMOVE ALL MAINTENANCE TOOLS** from the immediate area prior to turning the machine ON.
23. **SECURE** all work. When it is possible, use clamps or jigs to secure the workpiece. This is safer than attempting to hold the workpiece with your hands.
24. **STAY ALERT**, watch what you are doing, and use common sense when operating any machine. **DO NOT** operate any machine tool while tired or under the influence of drugs, alcohol, or medication. A moment of inattention while operating power tools may result in serious personal injury.

25. **USE ONLY** recommended accessories. Use of incorrect or improper accessories could cause serious injury to the operator and cause damage to the machine. If in doubt, **DO NOT** use it.
26. Wear proper clothing, **DO NOT** wear loose clothing, gloves, neckties, or jewelry. These items can get caught in the machine during operations and pull the operator into the moving parts. Users must wear a protective cover on their hair, if the hair is long, to prevent it from contacting any moving parts.
27. **SAVE** these instructions and refer to them frequently and use them to instruct other users.
26. **THE USE** of extension cords is not recommended for 230V equipment. It is better to arrange the placement of your equipment and the installed wiring to eliminate the need for an extension cord. If an extension cord is necessary, refer to the chart in the Grounding Instructions section to determine the minimum gauge for the extension cord. The extension cord must also contain a ground wire and plug pin.

29. Information regarding the safe and proper operation of this tool is also available from the following sources:

Power Tool Institute
 1300 Summer Avenue
 Cleveland, OH 44115-2851
www.powertoolinstitute.org

National Safety Council
 1121 Spring Lake Drive
 Itasca, IL 60143-3201

American National Standards Institute
 25 West 43rd. St, 4th Floor
 New York, NY. 10036
 ANSI 01.1 Safety Requirements
 For Woodworking Machines
WWW.ANSI.ORG

U.S. Department of Labor Regulations
 OSHA 1910.213 Regulations
WWW.OSHA.GOV

PRODUCT SAFETY

1. Serious personal injury may occur if normal safety precautions are overlooked or ignored. Accidents are frequently caused by lack of familiarity or failure to pay attention. Obtain advice from supervisor, instructor, or another qualified individual who is familiar with this machine and its operations.
2. Every work area is different. Always consider safety first, as it applies to your work area. Use this machine with respect and caution. Failure to do so could result in serious personal injury and damage to the machine.
3. Prevent electrical shock. Follow all electrical and safety codes, including the National Electrical Code (NEC) and the Occupational Safety and Health Regulations (OSHA). All electrical connections and wiring should be made by qualified personnel only.
6. Safety decals are on this machine to warn and direct you to how to protect yourself or visitors from personal injury. These decals **MUST** be maintained so that they are legible. **REPLACE** decals that are not legible.
7. **DO NOT** leave the unit plugged into the electrical outlet. Unplug the unit from the outlet when not in use and before servicing, performing maintenance tasks, or cleaning.
8. **ALWAYS** turn the power switch "OFF" before unplugging the wide belt sander.

▲ WARNING



4. **TO REDUCE** the risk of electrical shock. **DO NOT** use this machine outdoors. **DO NOT** expose to rain or moisture. Store indoors in a dry area.

▲ WARNING

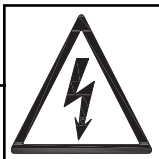

9. **DO NOT** handle the plug or wide belt sander with wet hands.

5. **STOP** using this machine, if at any time you experience difficulties in performing any operation. Contact your supervisor, instructor or machine service center immediately.
10. **USE** accessories only recommended by Steel City.
11. **DO NOT** pull the wide belt sander by the power cord. **NEVER** allow the power cord to come in contact with sharp edges, hot surfaces, oil or grease.
12. **DO NOT** unplug the wide belt sander by pulling on the power cord. **ALWAYS** grasp the plug, not the cord.

13. **REPLACE** a damaged cord immediately. **DO NOT** use a damaged cord or plug. **DO NOT USE** if the wide belt sander is not operating properly, or has been damaged, left outdoors or has been in contact with water.
14. **DO NOT** use the wide belt sander as a toy. **DO NOT** use near or around children.
15. **ALWAYS** wear eye protection. The operation of any wide belt sander can result in debris being thrown into your eyes, causing severe eye damage. Everyday glasses are not safety glasses. Wear safety glasses that comply with ANSI standard Z87.1
16. **KEEP** hands and clothing away from the rotating drum, belts and pulleys. **NEVER** place hands under the drum or dust cover.
17. **ALWAYS** feed workpieces against the rotation of the drum.
18. **HOLD** workpieces firmly and be aware of the possibility of kickback.
19. **DO NOT** make passes deeper than recommended in the specifications to avoid damage to the machine.
20. **NEVER** operate the machine without the dust cover in position.
21. **ALWAYS** stand to one side of the workpiece; **NEVER** stand directly in line with it.
22. **NEVER** force the workpiece into the sander; allow the feed belt to move the workpiece at the proper speed.
23. **MAKE SURE** that the workpiece has no loose knots, screws, nails or other foreign objects that might damage the feed belt or sanding drum.
24. **ALWAYS** keep bystanders and yourself away from the infeed and outfeed ends when a workpiece is fed into the sander.
25. **ALWAYS** keep your hands away from the sanding drum during operation.
26. **ALWAYS** keep fingers away from the conveyor and the underside of the workpiece during sander and conveyor operation.
27. **ALWAYS** adjust the conveyor feed rate and sanding drum height, so when you feed the workpiece into the sander using light pressure, you do not overload the sander. **NEVER** force the workpiece into the sander.
28. **ALWAYS** shut the sander down, let the sanding belt come to a complete stop, and disconnect power before you service, adjust, troubleshoot, or leave the machine unattended.
29. **ALWAYS** keep this machine in correct adjustment and properly serviced. **NEVER** attempt to clear a jammed workpiece while the sander is running.
30. **ALWAYS** replace the sandpaper when it is worn, and use only undamaged sandpaper.
31. **NEVER** sand if there is any doubt about the stability or integrity of the workpiece.
32. **NEVER** sand stock that is less than 1/4" thick.
33. **NEVER** adjust the conveyor belt tracking when the sanding drum is engaged.
34. **NEVER** use the sander without a dust collection system.

ELECTRICAL REQUIREMENTS

WARNING

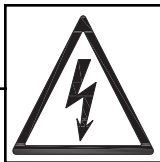

To reduce the risk of electric shock, follow all electrical and safety codes, including the National Electric Code (NEC) and the Occupational Safety and Health Regulations (OSHA). All electrical connections and wiring should be made by qualified personnel only.

The switch provided with your wide belt sander is designed to plug in to a 230V outlet. Since there are many different configurations for 230V plugs, it is conceivable that the configuration of your 230V outlet may not match the configuration of the plug. If this is the case, you will have to replace the plug with a UL/CSA approved plug that matches the configuration of your 230V outlet.

DO NOT connect the machine to the power source until you have completed the setup process.

GROUNDING INSTRUCTIONS

⚠ WARNING



This machine **MUST BE GROUNDED** while in use to protect the operator from electric shock.

In the event of a malfunction or breakdown, **GROUNDING** provides the path of least resistance for electric current and reduces the risk of electric shock. The plug **MUST** be plugged into a matching electrical receptacle that is properly installed and grounded in accordance with **ALL** local codes and ordinances.

If a plug is provided with your machine **DO NOT** modify the plug. If it will not fit your electrical receptacle, have a qualified electrician install the proper connections to meet all electrical codes local and state. All connections must also adhere to all of OSHA mandates.

IMPROPER ELECTRICAL CONNECTION of the equipment-grounding conductor can result in risk of electric shock. The conductor with the green insulation (with or without yellow stripes) is the equipment-grounding conductor. **DO NOT** connect the equipment-grounding conductor to a live terminal.

Check with a qualified electrician or service personnel if you do not completely understand the grounding instructions, or if you are not sure the tool is properly grounded.

PLUGS/RECEPTACLES

⚠ WARNING



- Electrocutation or fire could result if this machine is not grounded properly or if the electrical configuration does not comply with local and state electrical codes.
- **MAKE CERTAIN** the machine is disconnected from power source before starting any electrical work.
- **MAKE SURE** the circuit breaker does not exceed the rating of the plug and receptacle.

The motor supplied with your machine is a 230 volt, 60 hertz, single phase motor. Never connect the green or ground wire to a live terminal.

A machine with a 230 volt plug should only be connected to an outlet having the same configuration as the plug.

EXTENSION CORDS

⚠ WARNING

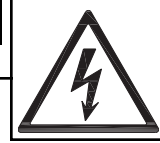

To reduce the risk of fire or electrical shock, use the proper gauge of extension cord. When using an extension cord, be sure to use one heavy enough to carry the current your machine will draw.

The smaller the gauge-number, the larger the diameter of the extension cord is. If in doubt of the proper size of an extension cord, use a shorter and thicker cord. An undersized cord will cause a drop in line voltage resulting in a loss of power and overheating.

⚠ WARNING

USE ONLY a 3-wire extension cord that has a 3-prong grounding plug and a 3-pole receptacle that accepts the machine's plug.

If you are using an extension cord outdoors, be sure it is marked with the suffix "W-A" ("W" in Canada) to indicate that it is acceptable for outdoor use.

Make certain the extension cord is properly sized, and in good electrical condition. Always replace a worn or damaged extension cord immediately or have it repaired by a qualified person before using it.

Protect your extension cords from sharp objects, excessive heat, and damp or wet areas.

MINIMUM RECOMMENDED GAUGE FOR EXTENSION CORDS (AWG)

230 VOLT OPERATION ONLY			
	25' LONG	50' LONG	100' LONG
0 to 6 Amps	16 AWG	16 AWG	14 AWG
6 to 8 Amps	16 AWG	16 AWG	12 AWG
8 to 12 Amps	14 AWG	14 AWG	10 AWG
12 to 15 Amps	12 AWG	12 AWG	10 AWG
15 to 20 Amps	10 AWG	10 AWG	Not recommended

UNPACKING & INVENTORY

⚠ WARNING

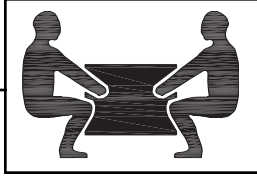

- The machine is heavy, two people are required to unpack and lift.

Check shipping carton and machine for damage before unpacking. Carefully remove packaging materials, parts and machine from shipping carton. Always check for and remove protective shipping materials around motors and moving parts. Lay out all parts on a clean work surface.

Remove any protective materials and coatings from all of the parts and the wide belt sander. The protective

coatings can be removed by spraying WD-40 on them and wiping it off with a soft cloth. This may need redone several times before all of the protective coatings are removed completely.

After cleaning, apply a good quality paste wax to any unpainted surfaces. Make sure to buff out the wax before assembly.

Compare the items to inventory figures; verify that all items are accounted for before discarding the shipping box.

⚠ WARNING

If any parts are missing, do not attempt to plug in the power cord and turn "ON" the machine. The machine should only be turned "ON" after all the parts have been obtained and installed correctly. **For missing parts, contact Steel City at 1-877-SC4-TOOL.**

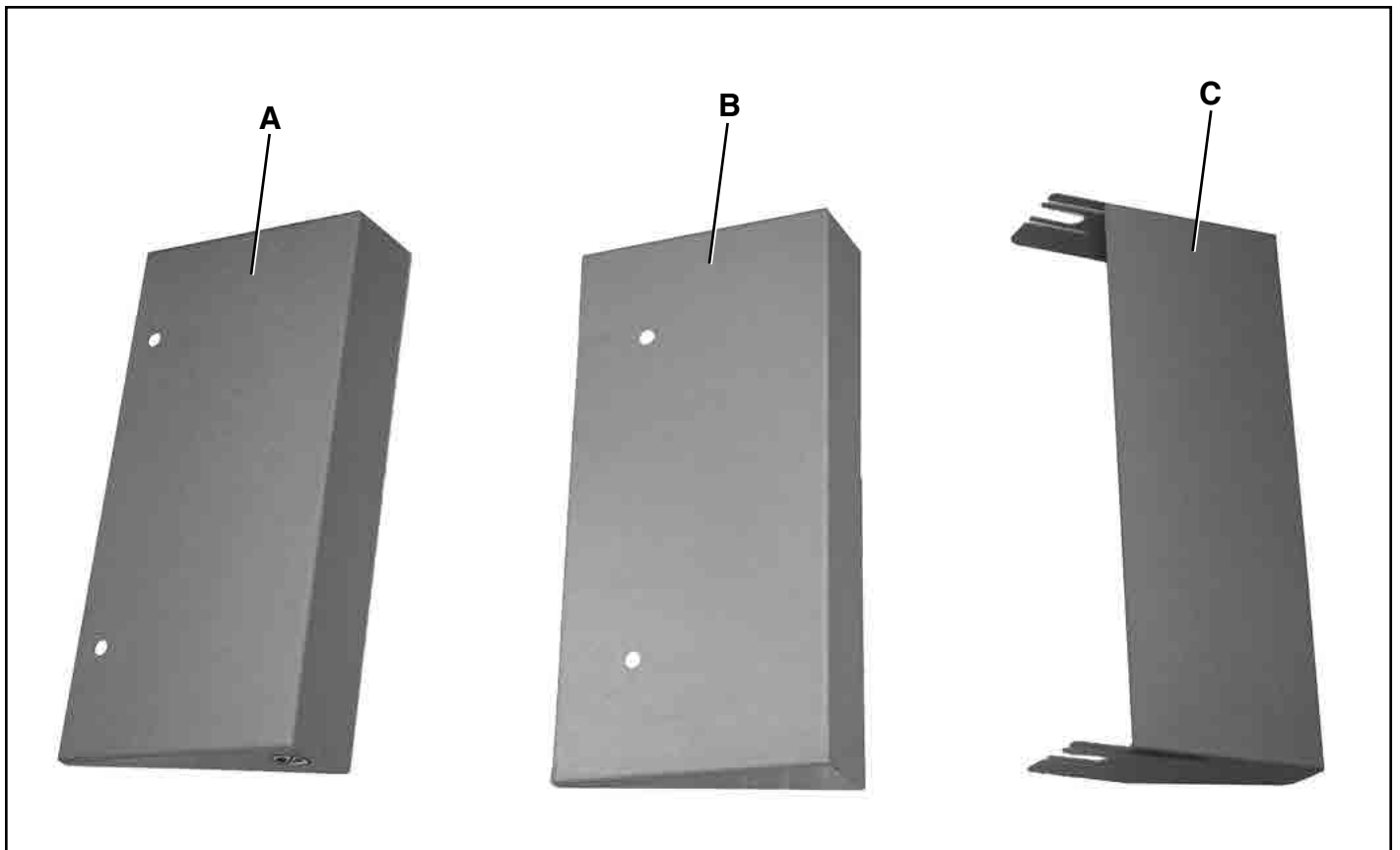

- A. Side Extension Table
- B. Rear Extension Table
- C. Front Extension Table

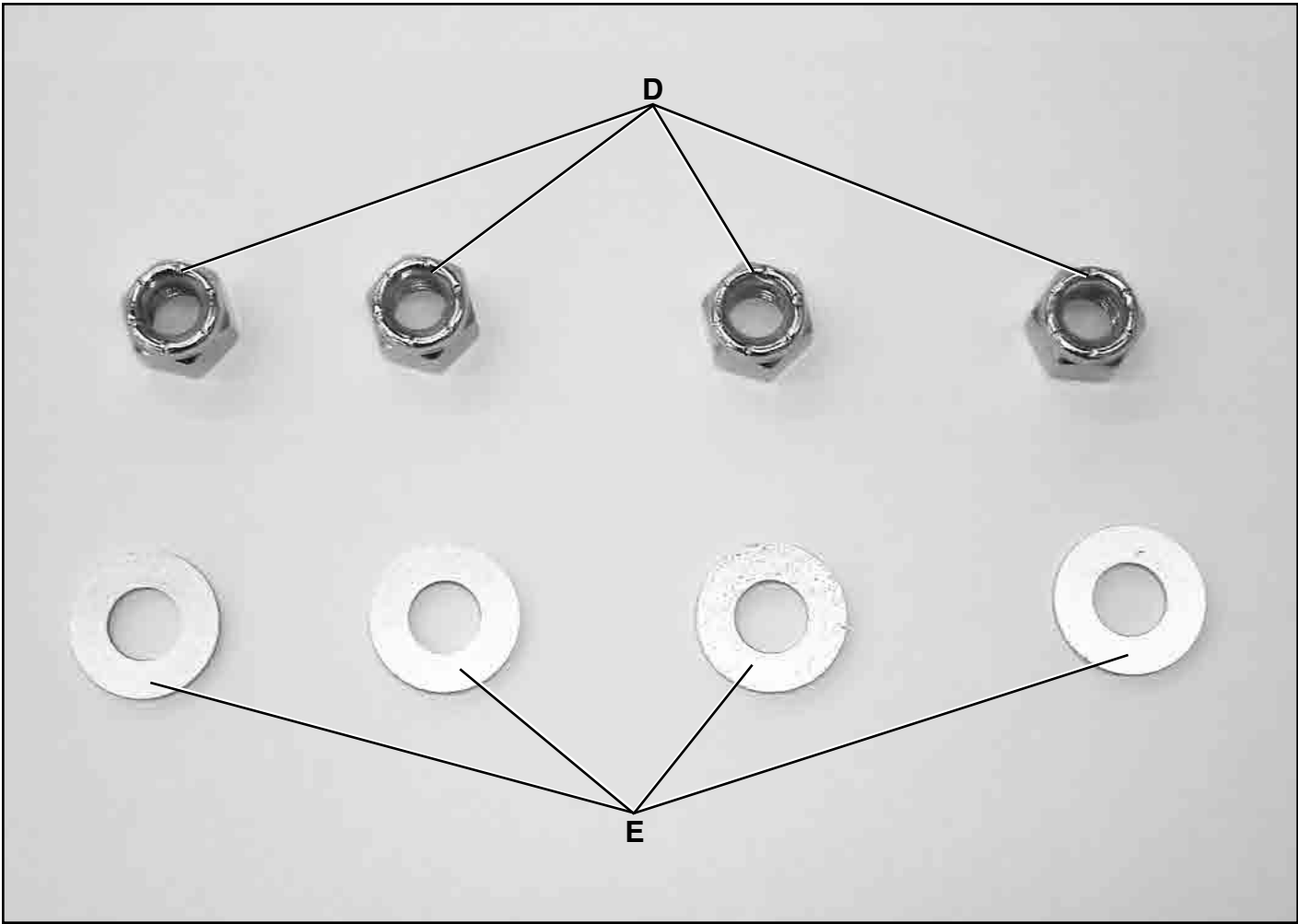

D. 1/2-12 Nylock Hex Nut (4)

E. 1/2" Flat Washer (4)

ASSEMBLY

ATTACHING THE EXTENSION TABLES

The extension tables provide support to the front, rear and side of the Wide Belt Sander. All three of these extension tables will need to be installed prior to operating the Sander.

NOTICE: The Rear Extension Table and the Side Extension table are very similar in appearance. If you place the two tables side by side, you will notice that the Side Extension Table has the two mounting holes closer to the bottom of the table than does the Rear Extension Table. Take care to use the correct table in the proper location.

1. Attach the Side Extension Table (A) to the two Support Bars (B) on the side of the Sander using the two 1/2-12 Nylock hex nuts (C) and two 1/2" Flat Washers provided. **SEE FIG. 1.**

Fig. 1

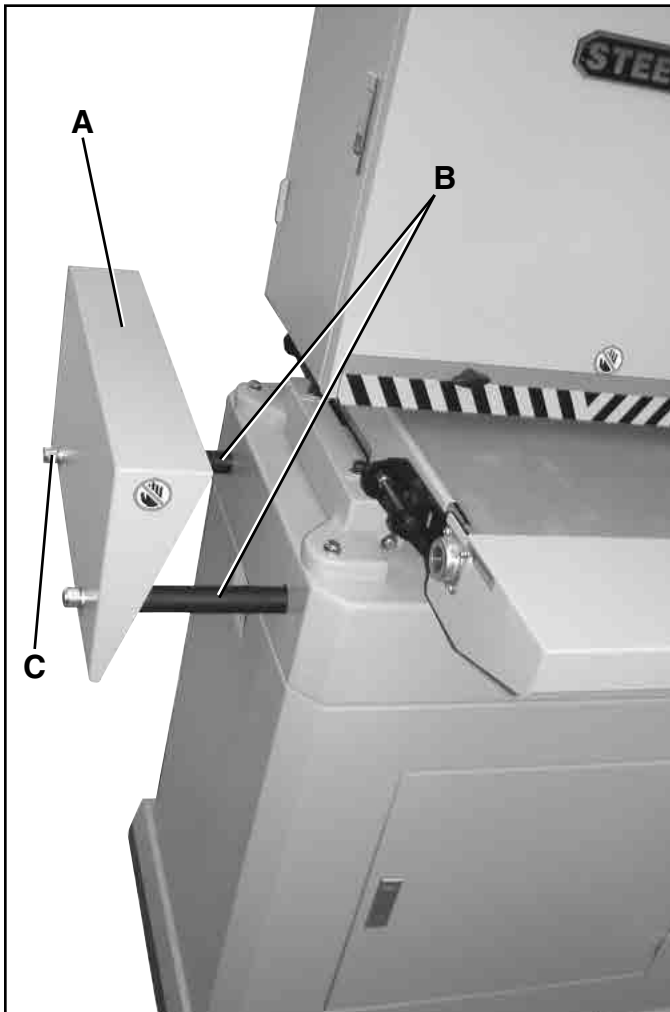

2. Attach the Rear Extension Table the same way you attached the Side Extension Table using the two 1/2-12 Nylock hex nuts and two 1/2" Flat Washers provided. **SEE FIG. 2.**

Fig. 2

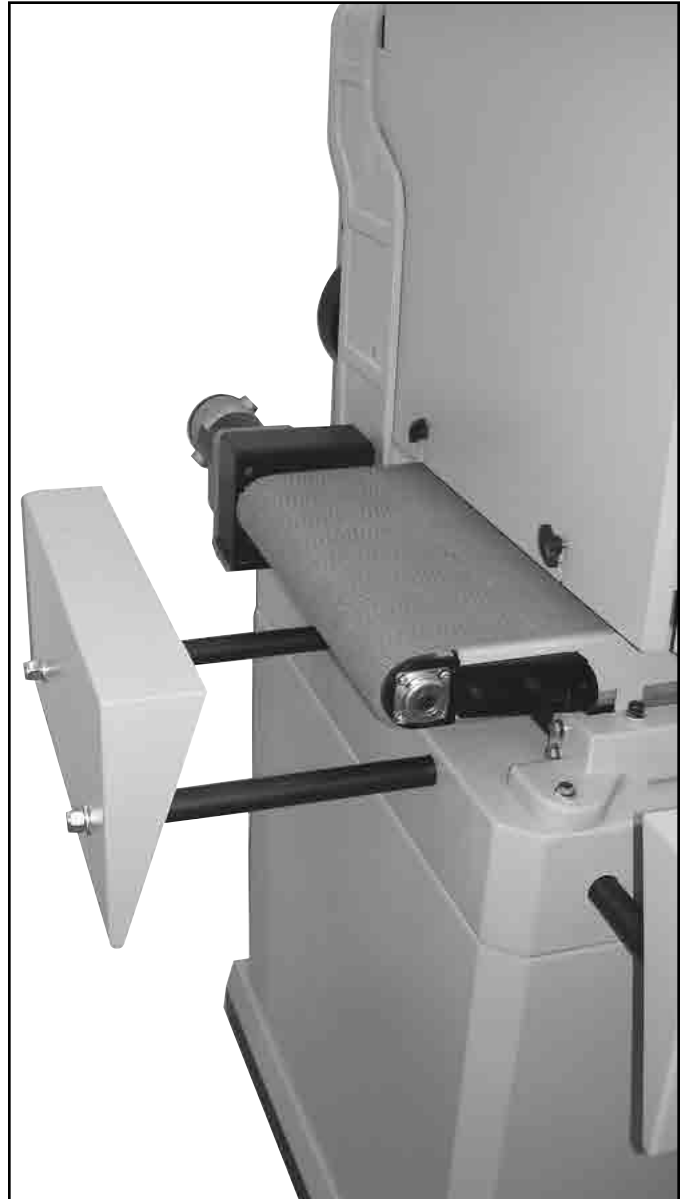

3. To attach the Front Extension Table, loosen the four Phillips head screws (D) located on both sides of the front conveyor belt roller. **SEE FIG. 3.**

Fig. 3

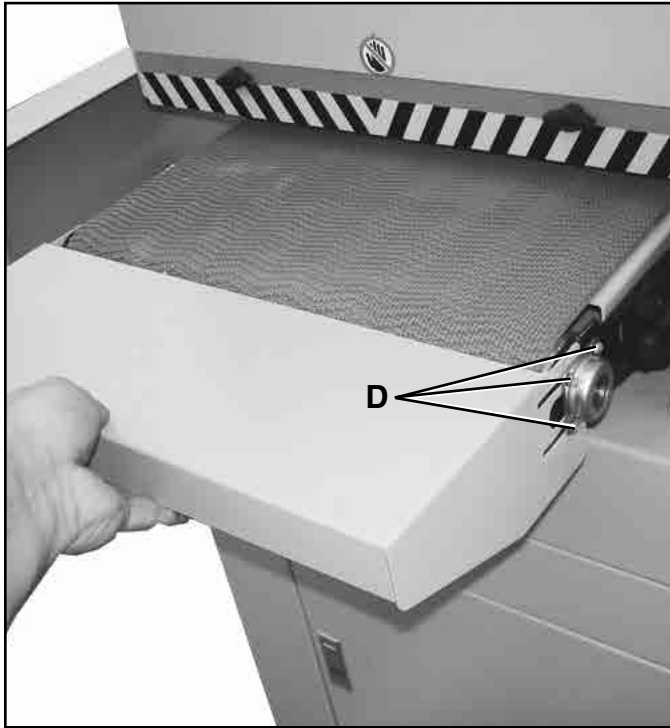

4. Line up the notches on the Front Extension Table with the screws you loosened in step 3 and slide the Front Extension Table forward as far as it will go. Make sure that the tabs of the Front Extension Table are on the inside on the Bearing Cap (E). Once the table is in place, retighten all Phillips head screws loosened in step 3. **SEE FIG. 3A.**

Fig. 3A

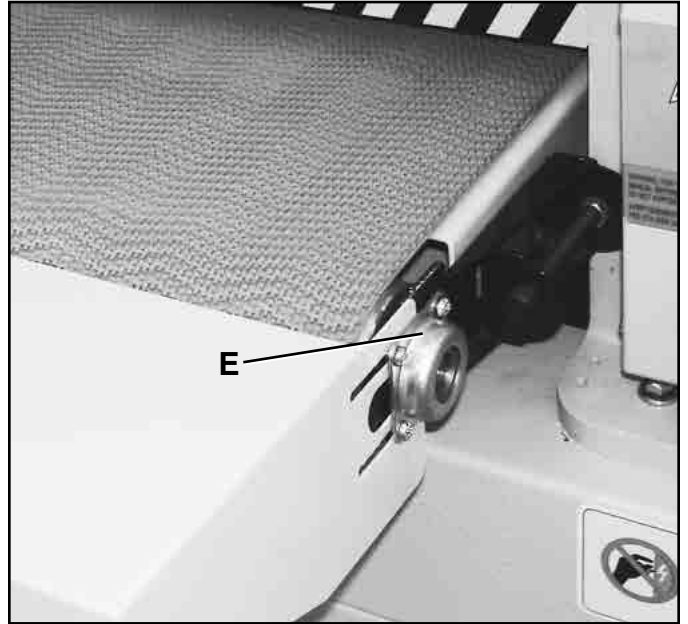

ADJUSTMENTS

NOTICE: There are a number of different adjustments on the Wide Belt Sander that you should become familiar with before operating the machine. Although all adjustments are preset at the factory, stresses may occur to the unit during shipping. It is recommended that you adjust or align your Sander using the following procedures to return it to optimal working conditions. Do not attempt to use this Sander until you have performed **ALL** of the adjustments in this section

REMOVING THE SANDING BELT

It is necessary to remove the Sanding Belt in order to accomplish some of the adjustments. Do not reinstall the Sanding Belt until instructed to do so.

⚠ WARNING

MAKE CERTAIN THAT THE SANDER IS DISCONNECTED FROM THE POWER SOURCE.

1. Remove the two knobs (A) on the front of the belt cover and place the guard (B) off to the side. **SEE FIG. 4.**

Fig. 4



2. Loosen the two knobs (not shown) on the back side of the machine. This will allow you to lift the Dust Cover off of the Sander.
3. With the Dust Cover now removed, loosen the Tension Locking Knob (C) and rotate the Hand-wheel (D) counterclockwise to take the tension off of the sanding belt. **SEE FIG. 4A.**

Fig. 4A

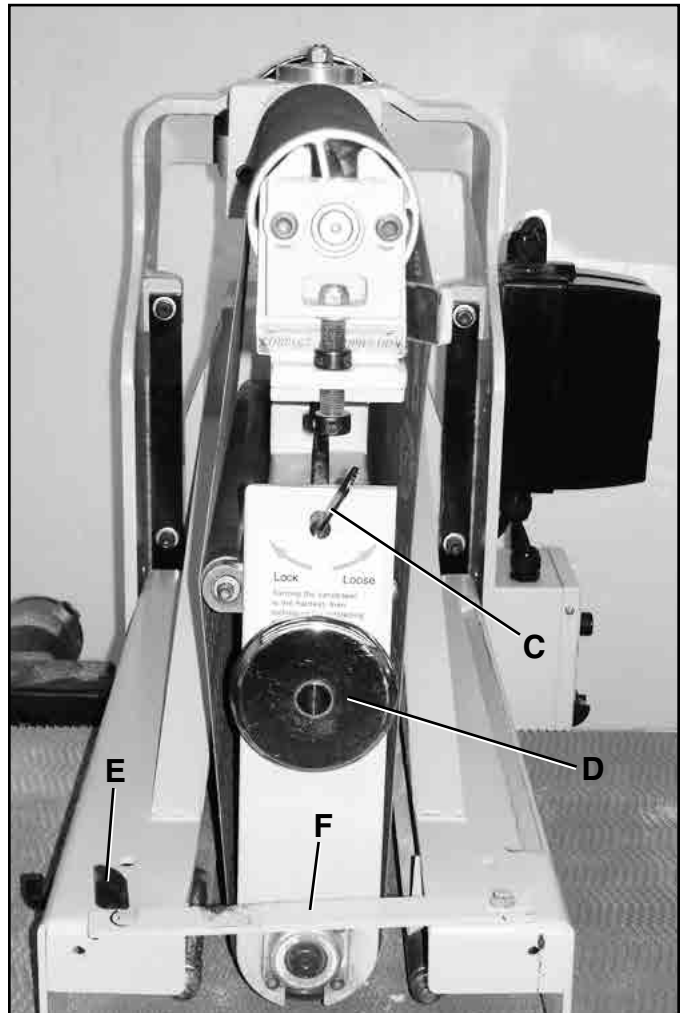

4. Loosen the Knob (E) and rotate the bar (F) out of the way.
5. The Sanding Belt can now be slid off of the upper and lower drums.

SANDING DRUM ALIGNMENT

The tightness of the Elevation Tension Adjustment Screws needs to be adjusted to allow for smooth height adjustments while still ensuring a tight enough fit to limit drum deflection. If the screws are too tight, sanding drum height adjustments will be difficult; however, if the screws are too loose, the drum will deflect, causing an uneven sanding surface.

⚠ WARNING

MAKE CERTAIN THAT THE SANDER IS DISCONNECTED FROM THE POWER SOURCE.

1. Loosen the hex nuts (not shown) on the backside of the Elevation Tension Adjustment Screws (G). **SEE FIG. 6.**
2. Loosen or tighten each screw as required. Make adjustments in 1/4 turn increments until the desired fit is achieved.
3. Retighten the hex nuts loosened in step 1.
4. With the proper tension set, make certain that the conveyor belt table (H) is parallel to the lower sanding drum (I). To do this, first, place two blocks of wood **OF EQUAL SIZE** on the conveyor belt at opposite ends of the sanding drum. **SEE FIG. 5.**

Fig. 5

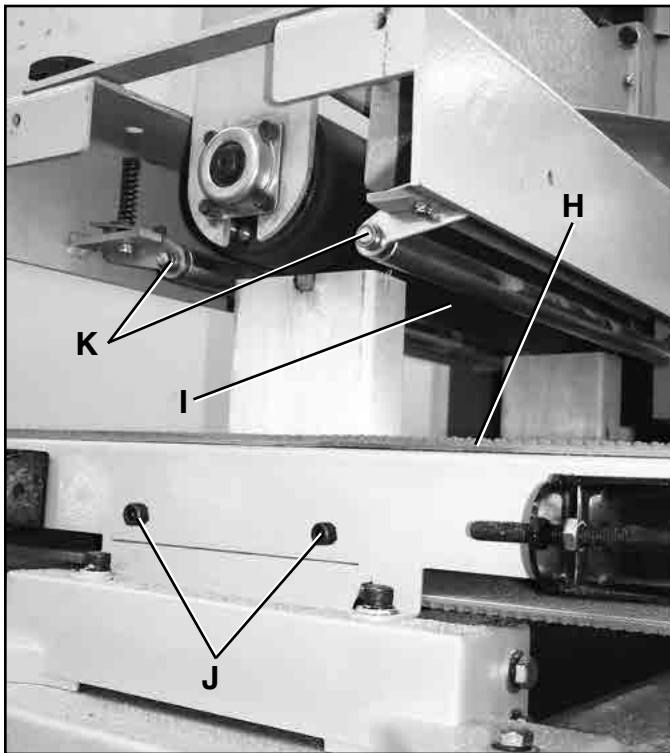

NOTICE: Make certain that both blocks of wood touch **ONLY** the lower sanding drum and not the infeed and outfeed pressure rollers (K).

5. Using the Sanding Drum Raise / Lower Handwheel, lower the drum until it just touches the blocks of wood.

6. Using a feeler gauge, check and see the clearance between the both blocks of wood and the drum. They should be within .010 of each other.
7. If an adjustment is necessary, loosen the two socket head cap screws (J) and adjust the table either up or down by either lifting up or pushing down on the table by hand. Once the table is in the desired position, retighten both socket head cap screws. **SEE FIG. 5.**
8. Recheck the clearance between the both blocks of wood and the drum. If the difference between the two measurements is less than .010, no further adjustment is necessary. If the difference between the two measurements is greater than .010, repeat step 7.

REINSTALLING THE SANDING BELT

⚠ WARNING

MAKE CERTAIN THAT THE SANDER IS DISCONNECTED FROM THE POWER SOURCE.

Once you have completed all of the preceding adjustments, you can now reinstall the sanding belt.

1. Loosen the handwheel (A) until you are able to fit the sanding belt over both the upper and lower drums. **SEE FIG. 6.**

Fig. 6

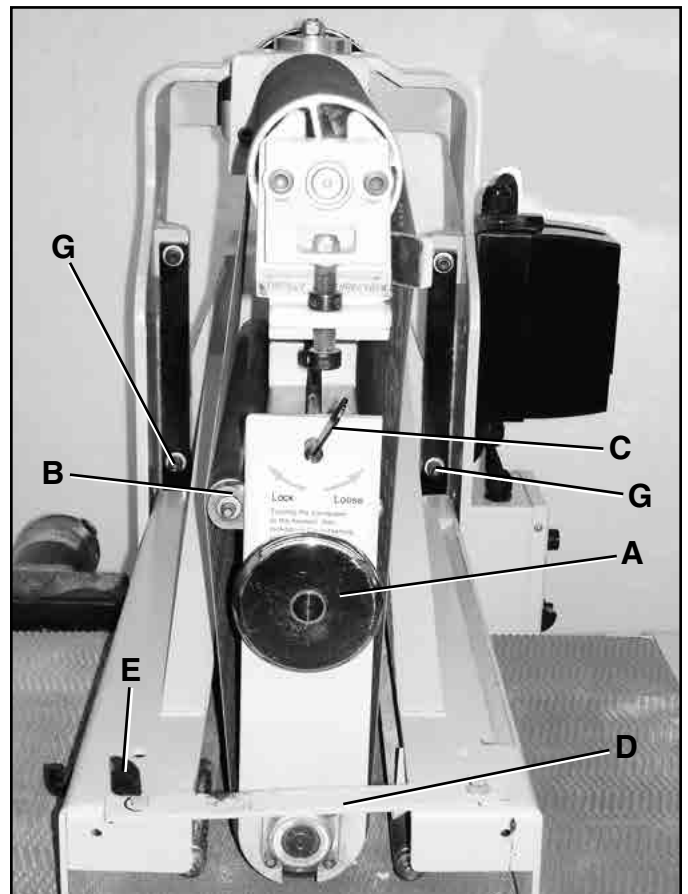

- Center the sanding belt on both the upper and lower drums.
- Tighten handwheel (A) enough so that there is firm tension on the belt. Press in on the guide roller (B) to make sure that it has some spring to it. The tension on the belt should be firm, but not so tight as to take away all of the spring action on the guide roller. **SEE FIG. 6, page 19.**
- With the belt tension set properly, rotate knob (C) clockwise to tighten it.
- Rotate the bar (D) into place and lock in place using the knob (E).

NOTICE: Do not replace the Dust Cover at this time. You will need to follow all of the steps in the **SETTING SANDING BELT TRACKING** section of this manual before the Dust Cover should be reinstalled.

SETTING SANDING BELT TRACKING

The Sander should now be connected to the power source.

- Turn the Wide Belt Sander on using the Power Switch (A). **SEE FIG. 7.**

Fig. 7

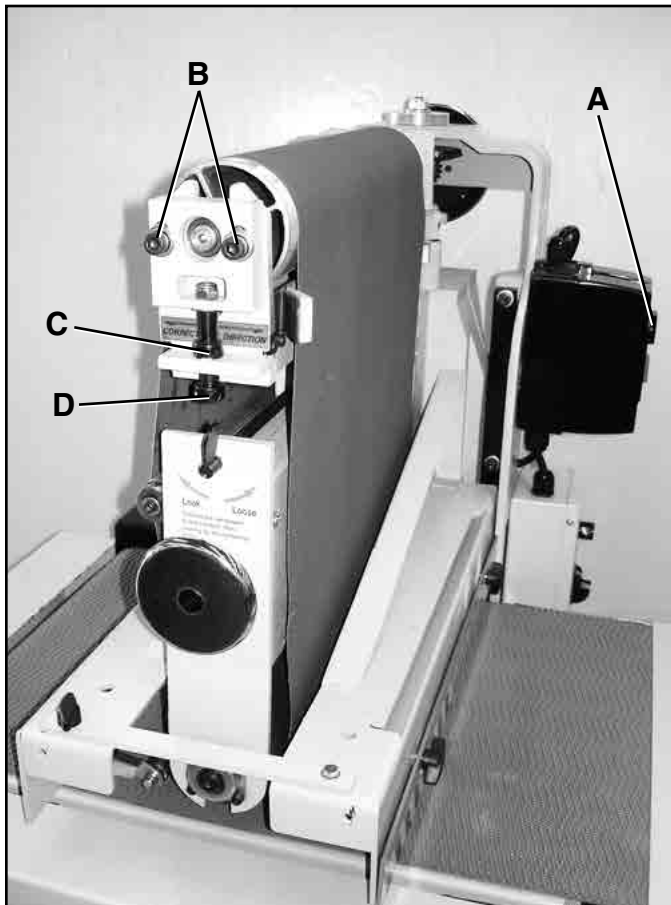

- Watch the belt closely as it rotates, checking to see if it favors one side or the other.
- If an adjustment is necessary, slightly loosen the two socket head cap screws (B).
- Loosen the nut (C) and using the provided adjusting tool (not shown) rotate the adjusting bolt (D). If the belt needs to track towards the outboard side (the side with the open end) of the machine, rotate the bolt clockwise. If the belt needs to track towards the inboard side of the machine, rotate the adjusting bolt counterclockwise.

NOTICE: When making tracking adjustments, do so in small increments. Limit your adjustments to 1/4 turn at a time. Adjustments may not be immediately apparent so give the belt time to respond to your adjustment.

- Once the tracking is properly set, retighten the two socket head cap screws (B) loosened in step 3.
- Turn the machine off and install the dust cover at this time. Make sure to reinstall the guard (A) that you removed and tighten down the four knobs (two in the front(B) and two in the rear of the Sander). **SEE FIG. 8.**

Fig. 8



CONVEYOR FEED BELT TRACKING ADJUSTMENT

Occasional adjustment to the conveyor belt tracking may be required due to stretching, normal wear and tear, and improper tensioning. Ideally, the conveyor belt should track in the center of the conveyor belt feed table.

1. Turn on the Drum Motor Power Switch first and then turn on the Conveyor Belt Power Switch.

NOTICE: The Conveyor Belt Power Switch will only operate while the sanding belt is running.

2. The conveyor belt tracking adjustment screws (A) are located at the front of the machine on both the right and left sides of the Wide Belt Sander. **SEE FIG. 9.**

Fig. 9

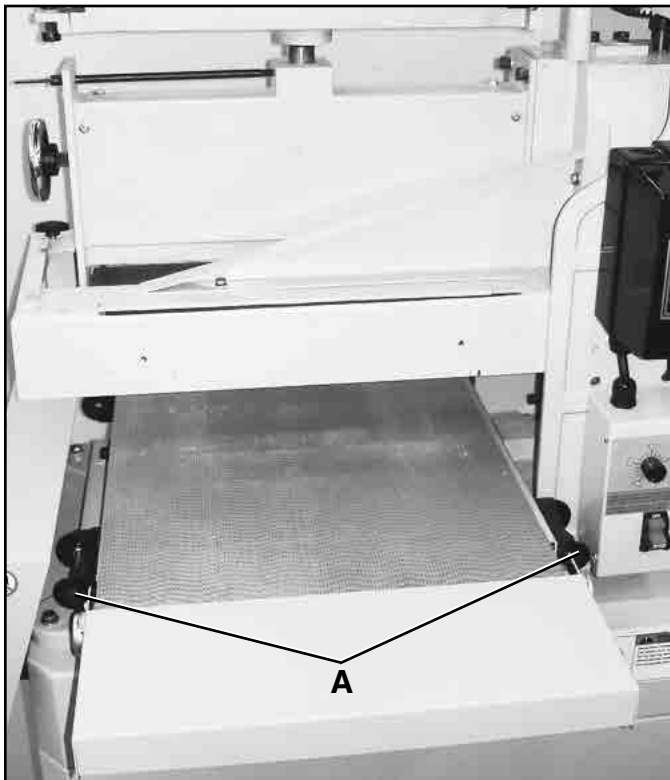

3. To increase the tension, the tracking screw must be rotated clockwise using a hex wrench (B). Turning the tracking screw counterclockwise reduces the tension. Note that it will be necessary to back off the hex nuts (C) in order to rotate the screw. **SEE FIG. 10.**

Fig. 10

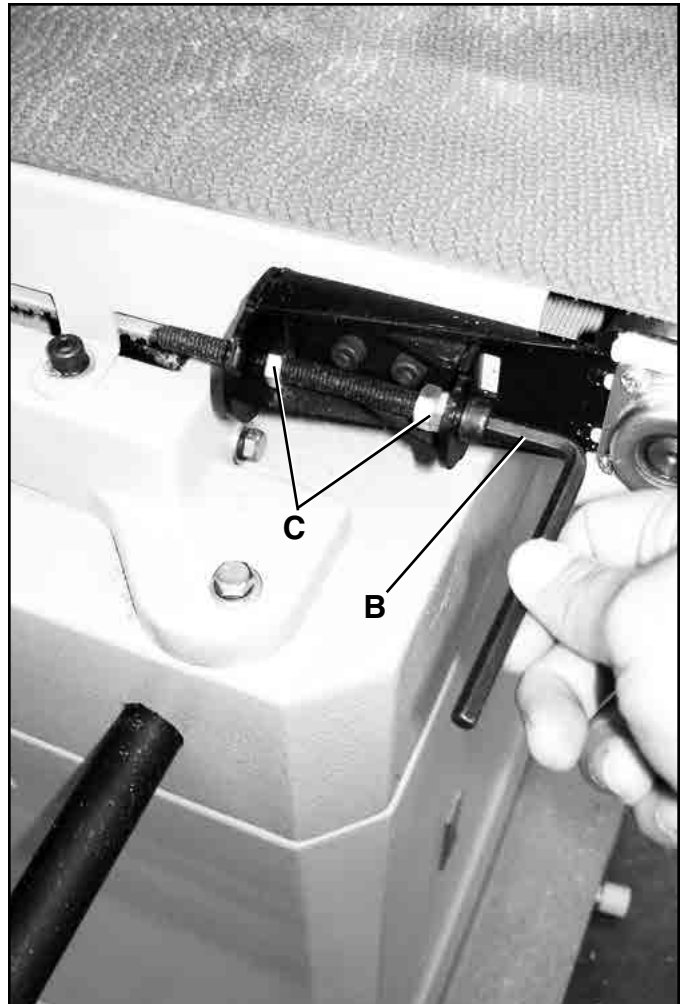

4. While the conveyor belt is moving, tighten the tracking screw on the side that the belt is tracking towards. For example if the belt is tracking toward the outboard side of the Sander, tighten the tracking adjustment screw on that side.

NOTICE: Tracking adjustments may not become apparent immediately. Increase the speed of the conveyor belt to hasten the effects of your adjustment. It is good practice to make adjustments in 1/4 turn increments.

OPERATIONS

RAISING AND LOWERING SANDING DRUM

The height of the sanding drum can be adjusted using the Raise / Lower Handwheel (A). Turning the handwheel clockwise lowers the drum, while turning the handwheel counterclockwise will raise the drum. Each full rotation of the Handwheel will either raise or lower the drum approximately 1/64". The depth setting can be measured using the Depth Indicator Scale (B) on the front of the machine. **SEE FIG. 11.**

Fig. 11

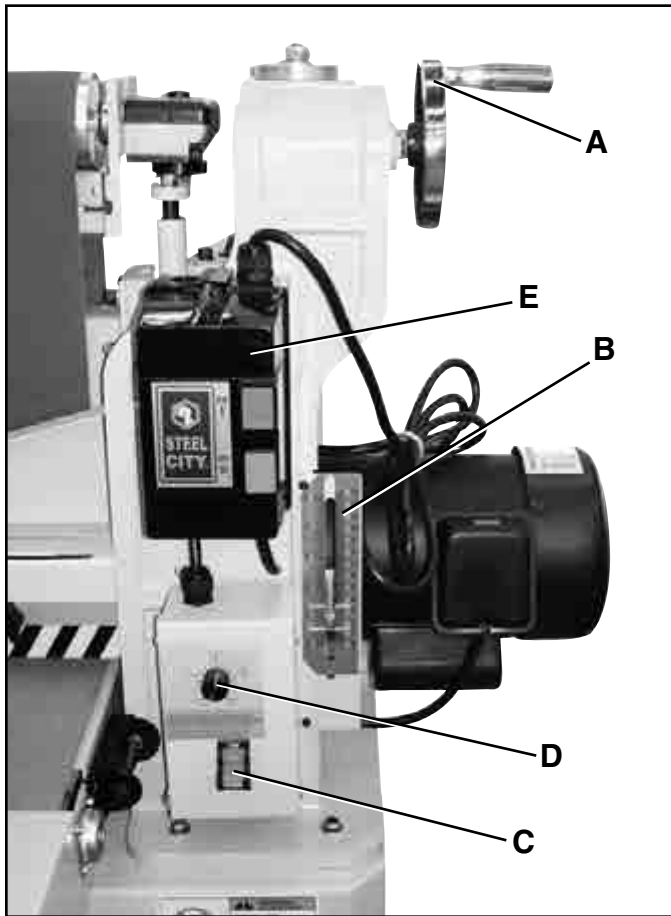

CONVEYOR BELT CONTROL

The Conveyor belt is turned on using the Conveyor Belt Power Switch (C). The Variable Speed Control Switch (D) lets you control the speed at which the conveyor belt moves. You can vary the speed of the belt up to 10 FPM (feet per minute). Keep in mind when selecting the feed rate, wider workpieces and harder wood will require a slower feed rate, while narrow or soft pieces can be put through the sander at a faster rate.

NOTICE: The Conveyor Belt will **ONLY** operate once the power for the sanding drum has been turned ON using the Drum Motor Power Switch (E).

GRIT SELECTION

The grit size of the sandpaper designates the coarseness of the abrasive. The lower the grit number, the coarser the abrasive. With coarser grit papers, such as 60 grit, very aggressive material removal and surface scratching occurs. With finer grit abrasives, very little material is removed and a buffed like look begins to appear. The table below shows different types of grit and their uses.

DESCRIPTION	NORMAL USE
60 Grit Sandpaper	surfacing and dimensioning boards, truing warped boards
80-100 Grit Sandpaper	surfacing, light dimensioning, removing planer ripples
120 Grit Sandpaper	light surfacing, minimal stock removal
150 Grit Sandpaper	finish sanding, minimal stock removal
180 Grit Sandpaper	finish sanding only, not for stock removal

DUST COLLECTION

This sander is equipped with a 4-in Dust Port located on the top of the machine suitable for connecting to a dust collection system. **NEVER** attempt to operate the Wide Belt Sander without a dust collector attached and running.

BASIC OPERATING PROCEDURE

The basic operating procedure for the Wide Belt Sander is as follows:

1. Place the workpiece on the conveyor belt and underneath the sanding drum.
2. Lower the Sanding Drum until the drum just touches the workpiece.
3. Remove the workpiece and set the depth of wood removal.
4. Turn ON the power to the Sanding Drum.
5. Turn ON the power to the Conveyor Belt.
6. Adjust the Conveyor belt to the proper speed.
7. Start up your dust collector.
8. Feed the workpiece through the sander.

Determining the depth of wood removal is one of the most important procedures for the Sander. It may take some experimentation to determine the proper depth, given the variables of abrasive grit, type of wood, and feed rate. Never remove more than 1/32" of material in a single pass. As a general rule, 1 full rotation of the handwheel, or 1/64" is recommended for coarser grits and softer woods. 1/2 rotation of the handwheel, or 1/128" may be more desirable with harder woods and/or finer grits of abrasives. For best results, use a scrap piece of wood to practice on. This will help you develop a familiarity with the machine before doing finish work.

MAINTENANCE

LUBRICATION

The motor on this unit has sealed bearings and requires no further lubrication.

Periodically, lubricate moving parts using a white lithium grease. These items include the threaded depth control (A) as well as all sliding surfaces. **SEE FIG. 12.**

Fig. 12

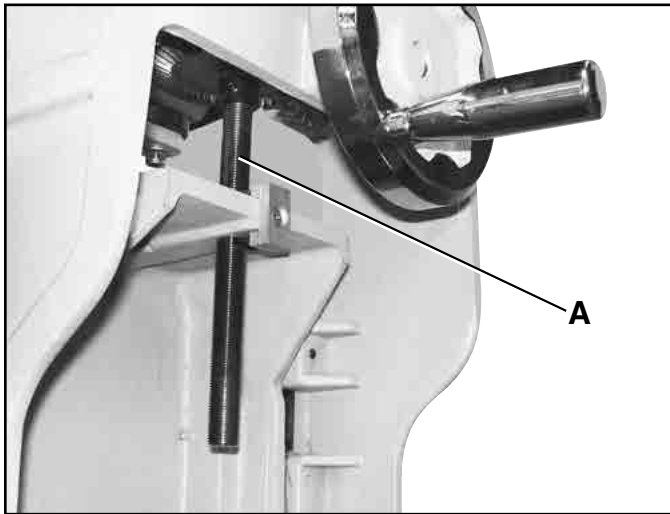

SANDING BELT REPLACEMENT

The Sanding Belt will need to be changed after a period of time due to normal wear and tear. It will also be common to change the Sanding Belt to switch to a different grit for different projects. The process of changing the Sanding Belt is covered in detail in the ADJUSTMENTS section of this User Manual. Refer specifically to the two sections labeled REMOVING THE SANDING BELT and REINSTALLING THE SANDING BELT for information on this procedure.

Once the new belt is installed, make sure to set the tracking properly. For more information on this refer the section titled SETTING SANDING BELT TRACKING in the ADJUSTMENTS section of this manual.

CONVEYOR FEED BELT REPLACEMENT

Common causes which require replacement of the Conveyor Feed Belt are:

1. Normal wear and tear.
2. Inadvertent contact with the Sanding Drum abrasive during operation.
3. Tearing of the belt due to mistracking.
4. Excessive buildup of non-removable film such as pitch or resin.

Fig. 13

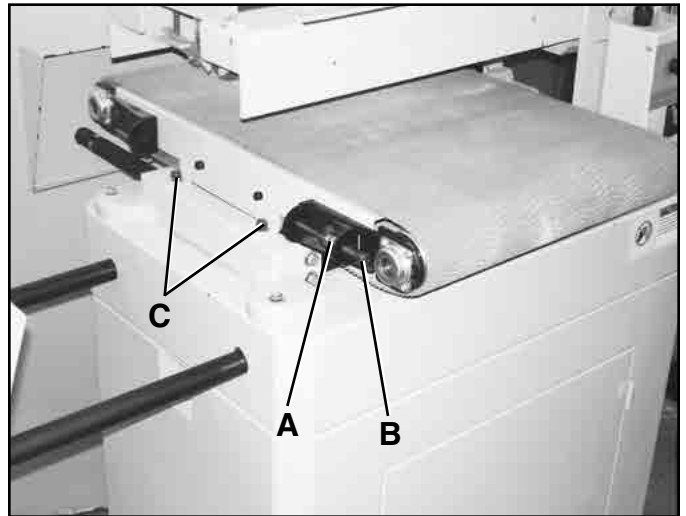

WARNING

MAKE CERTAIN THAT THE SANDER IS DISCONNECTED FROM THE POWER SOURCE.

1. Loosen the hex nuts (A) on the Tracking Adjustment Screws (B) and rotate the nuts toward the middle of the adjustment screw. **SEE FIG. 13.**

NOTICE: Only the left side adjustment screw is shown in **FIG. 13**, however, the same procedure should be done to the right side adjustment screw on the front roller as well.

2. Loosen the Tracking Adjustment Screws until enough tension is removed from the conveyor belt.
3. Remove the two socket head cap screws (C) from the machine.
4. Remove the Conveyor Belt by grasping both sides of the belt and working the belt off of the front and rear rollers.
5. With the old belt now removed, work the new belt onto the front and rear rollers and center it on the rollers.
6. Reinstall the two socket head cap screws (C) removed in step 3.
7. Retention the belt using the Tracking Adjustment Screws.

Once the new belt is installed, be sure to check and/or adjust the tracking of the conveyor belt. Detailed instructions for this are in the CONVEYOR FEED BELT TRACKING ADJUSTMENT section in the ADJUSTMENTS section of this manual.

TROUBLESHOOTING GUIDE

PROBLEM	LIKELY CAUSE(S)	SOLUTION
Sanding belt clogs quickly	<ol style="list-style-type: none"> 1. Grit is too fine 2. Too much material being sanded off 3. Wood is too dirty or oily 	<ol style="list-style-type: none"> 1. Use coarser grit 2. Reduce sanding depth 3. Use dry stock
Edges of workpiece round over when sanding	<ol style="list-style-type: none"> 1. Too much material being removed 	<ol style="list-style-type: none"> 1. Reduce sanding depth
Thickness differs on the left and right sides of the workpiece	<ol style="list-style-type: none"> 1. Conveyor belt table is not parallel to the lower drum 	<ol style="list-style-type: none"> 1. Adjust table parallel to lower drum
Thickness differs on the front and back sides of the workpiece	<ol style="list-style-type: none"> 1. Feed rate too fast 2. Too much material being removed 3. Sandpaper grit too fine 	<ol style="list-style-type: none"> 1. Reduce feed rate 2. Reduce sanding depth 3. Use coarser grit
Workpiece slips on conveyor belt	<ol style="list-style-type: none"> 1. Too little pressure on workpiece 2. Sanding belt clogged with dust 3. Excessive buildup on conveyor belt 	<ol style="list-style-type: none"> 1. Adjust sanding depth to increase pressure 2. Blow out dust with high pressure air 3. Clean or replace conveyor belt
Straight grooves on workpiece	<ol style="list-style-type: none"> 1. Dirty pressure roller 2. Lower drum scratched 	<ol style="list-style-type: none"> 1. Clean pressure roller 2. Replace lower drum <p>NOTE: #2 should be performed by a qualified technician</p>
“Snake” marks on workpiece	<ol style="list-style-type: none"> 1. Sanding belt partially damaged 	<ol style="list-style-type: none"> 1. Replace Sanding Belt

◆ NOTES ◆

PARTS

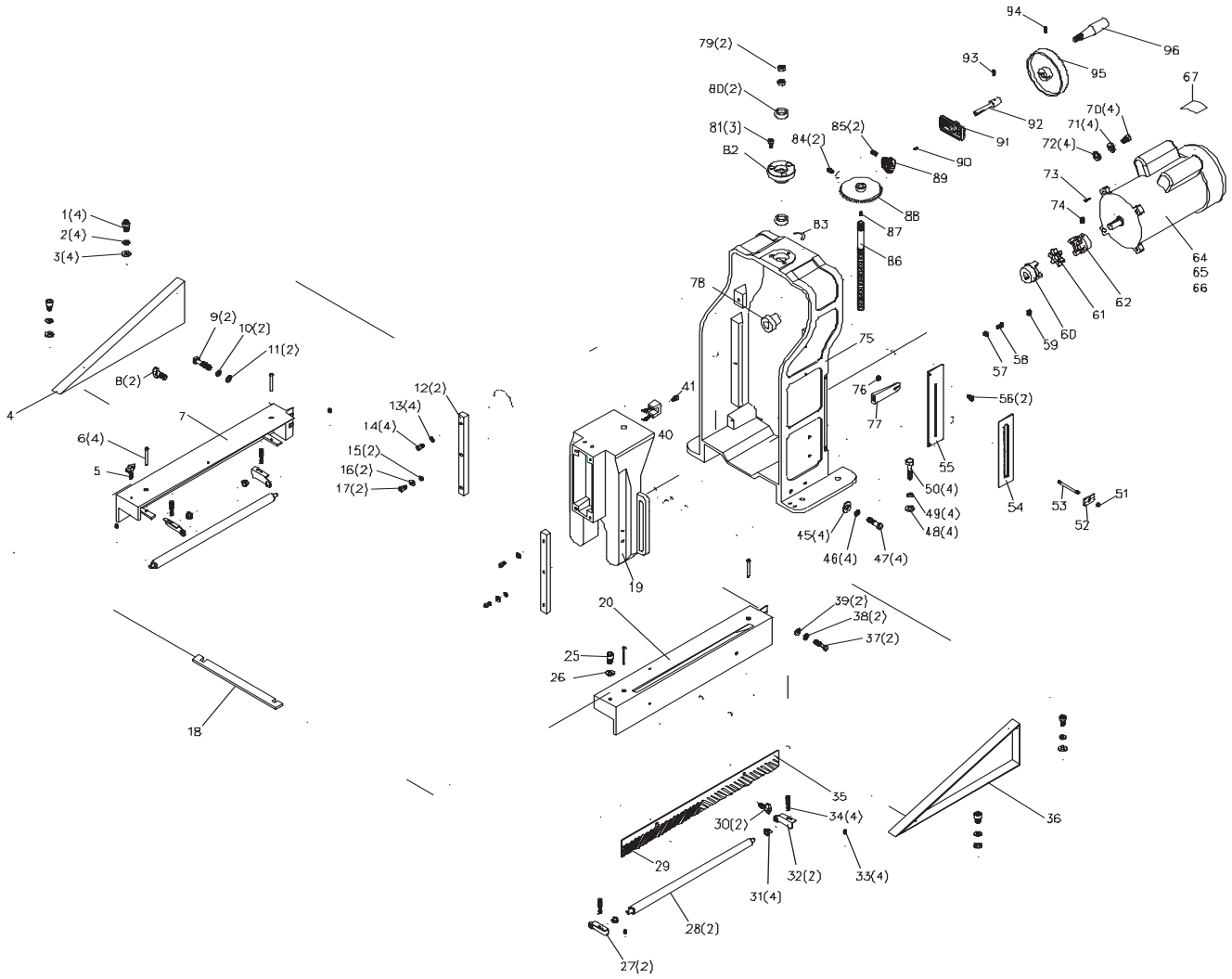

KEY NO.	PART NO.	DESCRIPTION	QTY.	KEY NO.	PART NO.	DESCRIPTION	QTY.
1	OR95052	SCR HEX SOC HD 1/4-20 x 1/2"	4	52	OR74050	INDICATOR	1
2	OR90070	WASHER LOCK 1/4"	4	53	OR74051	INDICATOR BAR	1
3	OR90060	WASHER FLAT 1/4"	4	54	OR74052	SCALE LABEL	1
4	OR74035	FIXED BRACKET (LEFT)	1	55	OR74053	INDICATOR SCALE	1
5	OR95053	SCR WING 1/4-20 x 5/8"	1	56	OR95058	SCR ROUND HD M4 x 10mm	2
6	OR94092	SCR PAN HD M5 x 80mm	4	57	OR95059	WASHER FLAT #8	1
7	OR74036	REAR GUIDE ROD BRACKET	1	58	OR95060	SCR ROUND HD #8-32 x 3/8"	1
8	OR95053	SCR WING 1/4-20 x 5/8"	2	59	OR91762	SCR HEX SOC SET 1/4-20 X 1/4"	1
9	OR90634	SCR HEX HD 5/16-18 X 1"	2	60	OR74054	COUPLER HEAD	1
10	OR90615	WASHER LOCK 5/16"	2	61	OR74055	COUPLING PLASTIC PAD	1
11	OR90625	WASHER FLAT 5/16"	2	62	OR74056	COUPLER	1
12	OR74037	GUIDE ROD	2	63	OR74057	MOTOR ASSY INC. REF: 64,65,66,67	1
13	OR90625	WASHER FLAT 5/16"	4	64	OR74058	MOTOR	1
14	OR95054	SCR HEX SOC HD 5/16-18 x 1-1/4"	4	65	OR74059	START CAP	1
15	OR90625	WASHER FLAT 5/16"	2	66	OR74060	RUN CAP	1
16	OR90615	WASHER LOCK 5/16"	2	67	OR74061	MOTOR PLATE	1
17	OR93846	SCR HEX SOC HD 5/16-18 x 1-1/2"	2	70	OR95054	SCR HEX SOC HD 5/16-18 x 1-1/4"	4
18	OR74038	HOLDING BRACKET PLATE	1	71	OR90615	WASHER LOCK 5/16"	4
19	OR74039	MOTOR BRACKET	1	72	OR90625	WASHER FLAT 5/16"	4
20	OR74040	FRONT GUIDE ROD BRACKET	1	73	OR95061	KEY 5X5X20	1
25	OR95052	SCR HEX SOC HD 1/4-20 x 1/2"	1	74	OR91762	SCR HEX SOC SET 1/4-20 X 1/4"	1
26	OR90060	WASHER FLAT 1/4"	1	75	OR74062	ARCH	1
27	OR74041	RIGHT POSITIONING PLATE	2	76	OR90381	NUT HEX M5 X 0.8	1
28	OR74042	HOLD DOWN BAR	2	77	OR74063	INDICATOR BRACKET	1
29	OR74043	BLOCK PLATE LABEL	1	78	OR74064	ARCH BUSHING	1
30	OR95053	SCR WING 1/4-20 x 5/8"	2	79	OR90280	NUT HEX M12	2
31	OR74044	REED ROLLER BEARING	4	80	OR95062	BEARING 6201	2
32	OR74045	LEFT POSITIONING PLATE	2	81	OR95054	SCR HEX SOC HD 5/16-18 x 1-1/4"	3
33	OR95055	SCR HEX SOC SET #10-24 x 3/8"	4	82	OR74065	BUSHING	1
34	OR74046	ADJUSTMENT SPRING	4	83	OR74066	ROTATION LABEL	1
35	OR74047	BLOCK PLATE	1	84	OR91762	SCR HEX SOC SET 1/4-20 X 1/4"	2
36	OR74048	FIXED BRACKET (RIGHT)	1	85	OR91762	SCR HEX SOC SET 1/4-20 X 1/4"	2
37	OR90634	SCR HEX HD 5/16-18 X 1"	2	86	OR74067	SCREW SHAFT	1
38	OR90615	WASHER LOCK 5/16"	2	87	OR95063	KEY 4x4x20	1
39	OR90625	WASHER FLAT 5/16"	2	88	OR74068	BEVEL GEAR (LARGE)	1
40	OR74049	BRUSH	1	89	OR74069	BEVEL GEAR (SMALL)	1
41	OR95056	SCR HEX SOC HD #10-24 x 5/8"	1	90	OR95064	KEY 4x4x20	1
45	OR90625	WASHER FLAT 5/16"	4	91	OR74070	BEARING BRACKET	1
46	OR90615	WASHER LOCK 5/16"	4	92	OR74071	HANDWHEEL ARBOR	1
47	OR95054	SCR HEX SOC HD 5/16-18 x 1-1/4"	4	93	OR95064	PIN SPRING 5X25	1
48	OR90625	WASHER FLAT 5/16"	4	94	OR91762	SCR HEX SOC SET 1/4-20 X 1/4"	1
49	OR90615	WASHER LOCK 5/16"	4	95	OR74072	HANDWHEEL	1
50	OR90634	SCR HEX HD 5/16-18 X 1"	3	96	OR74073	HANDLE	1
51	OR95057	NUT HEX CAP M5 X 0.8	1				

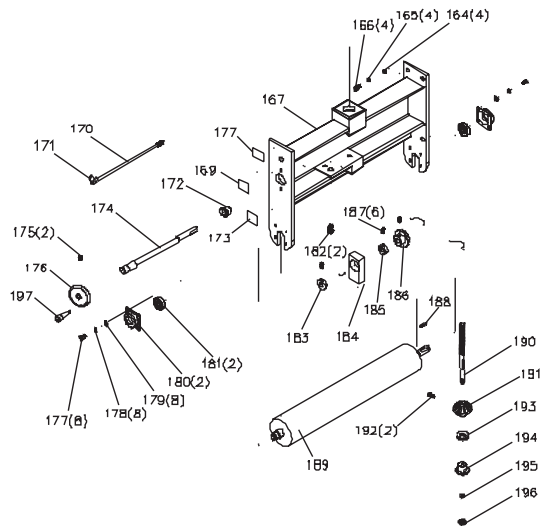
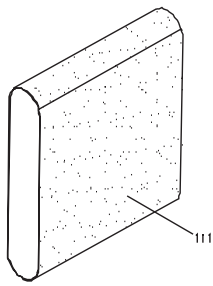
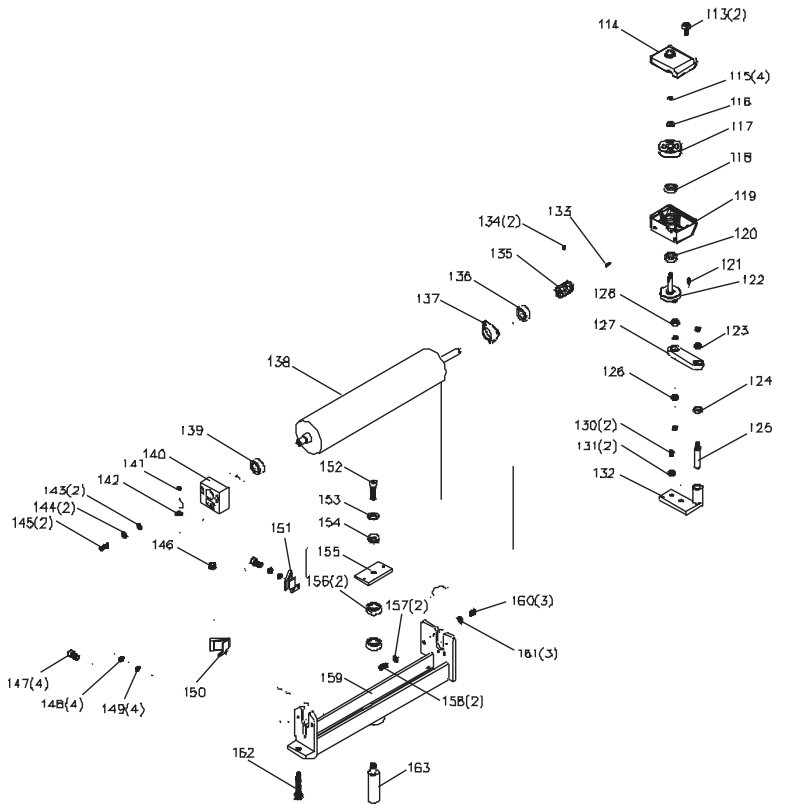
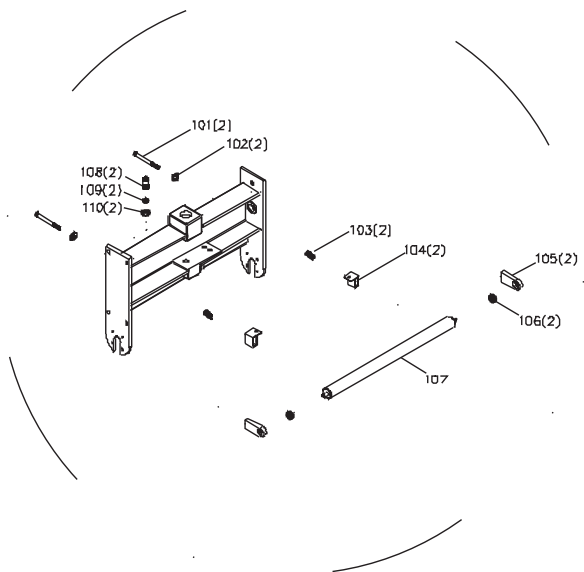

KEY NO.	PART NO.	DESCRIPTION	QTY.	KEY NO.	PART NO.	DESCRIPTION	QTY.
101	OR95065	SCR ROUND HD 1/4-20 x 1-3/4"	2	150	OR74094	TRACKING BLOCK (LEFT)	1
102	OR90070	WASHER LOCK 1/4"	2	151	OR74095	TRACKING BLOCK (RIGHT)	1
103	OR74074	SPRING	2	152	OR95074	SCR HEX SOC HD 3/8-18 x 1-1/2"	1
104	OR74075	FIXED ADJUSTMENT BLOCK	2	153	OR95075	WASHER FLAT 3/8" X 22"	1
105	OR74076	ADJUSTMENT BLOCK	2	154	OR95076	BEARING 51100	1
106	OR95066	BEARING 6800	2	155	OR74096	PRESSURE PLATE	1
107	OR74077	TENSION BAR	1	156	OR95077	BEARING 6003	2
108	OR95052	SCR HEX SOC HD 1/4-20 x 1/2"	2	157	OR90070	WASHER LOCK 1/4"	2
109	OR90070	WASHER LOCK 1/4"	2	158	OR95052	SCR HEX SOC HD 1/4-20 x 1/2"	2
110	OR90060	WASHER FLAT 1/4"	2	159	OR74097	UPPER ROLLER BRACKET	1
111	OR74078	SANDING BELT	1	160	OR95078	SCR HEX SOC HD M4 x 12mm	3
112	OR74079	GEAR BOX ASSY INC REF: 113 THRU 128	1	161	OR90077	WASHER LOCK M4	3
113	OR95067	SCR HEX HD M5 x 40mm	2	162	OR74098	ADJUSTMENT SCREW	1
114	OR74080	GEAR BOX COVER	1	163	OR74099	ROLLER BRACKET SHAFT	1
115	OR94049	NUT NYLOK 5/16"	4	164	OR90625	WASHER FLAT 5/16"	4
116	OR90625	WASHER FLAT 5/16"	1	165	OR90615	WASHER LOCK 5/16"	4
117	OR74081	WORM GEAR	1	166	OR95079	SCR HEX SOC HD 5/16-18 x 3/4"	4
118	OR95068	BEARING 6001	1	167	OR74100	LOWER ROLLER BRACKET	1
119	OR74082	GEAR BOX HOUSING	1	168	OR74101	LABEL	1
120	OR95068	BEARING 6001	1	169	OR74102	INSTRUCTION LABEL	1
121	OR95069	KEY 4X4X15	1	170	OR74103	TENSION BAR	1
122	OR74083	GEAR BOX ARBOR	1	171	OR74104	FLAT HANDLE	1
123	OR74084	BUSHING	1	172	OR74105	BUSHING	1
124	OR95066	BEARING 6800	1	173	OR74106	HANDLE LABEL	1
125	OR74085	CONNECTING PLATE SHAFT	1	174	OR74107	HANDLE SHAFT	1
126	OR74086	BUSHING	1	175	OR95080	SCR HEX SOC SET M4 x 8mm	2
127	OR74087	CONNECTING PLATE	1	176	OR74108	SMALL HAND WHEEL	1
128	OR95066	BEARING 6800	1	177	OR95073	SCR HEX SOC HD #10-24 x 1/2"	8
130	OR95054	SCR HEX SOC HD 5/16-18 x 1-1/4"	2	178	OR90145	WASHER LOCK M5	8
131	OR90625	WASHER FLAT 5/16"	2	179	OR90462	WASHER FLAT M5	8
132	OR74088	BRACKET	1	180	OR74109	BEARING CAP	2
133	OR95070	KEY 5X5X40	1	181	OR95072	BEARING 6202	2
134	OR95071	SCR HEX SOC SET #10-24 x 5/16"	2	182	OR95052	SCR HEX SOC HD 1/4-20 x 1/2"	2
135	OR74089	WORM SHAFT	1	183	OR74110	POSITIONING RING	1
136	OR95072	BEARING 6202	1	184	OR74111	ADJUSTMENT BLOCK	1
137	OR74090	BEARING HOUSING	1	185	OR74112	POSITIONING RING	1
138	OR74091	UPPER ROLLER	1	186	OR74113	BEVEL GEAR	1
139	OR95072	BEARING 6202	1	187	OR91762	SCR HEX SOC SET 1/4-20 X 1/4"	6
140	OR74092	ADJUSTMENT BLOCK	1	188	OR95061	KEY 5X5X20	1
141	OR94049	NUT NYLOK 5/16"	1	189	OR74114	LOWER BELT ROLLER	1
142	OR90060	WASHER FLAT 1/4"	1	190	OR74115	WORM GEAR SHAFT	1
143	OR90625	WASHER FLAT 5/16"	2	191	OR74116	BEVEL GEAR	1
144	OR90615	WASHER LOCK 5/16"	2	192	OR91762	SCR HEX SOC SET 1/4-20 X 1/4"	2
145	OR95054	SCR HEX SOC HD 5/16-18 x 1-1/4"	2	193	OR95076	BEARING 51100	1
146	OR74093	ADJUSTMENT NUT	1	194	OR74117	BUSHING	1
147	OR95073	SCR HEX SOC HD #10-24 x 1/2"	4	195	OR90625	WASHER FLAT 5/16"	1
148	OR90145	WASHER LOCK M5	4	196	OR94049	NUT NYLOK 5/16"	1
149	OR90462	WASHER FLAT M5	4	197	OR74200	HANDLE	1

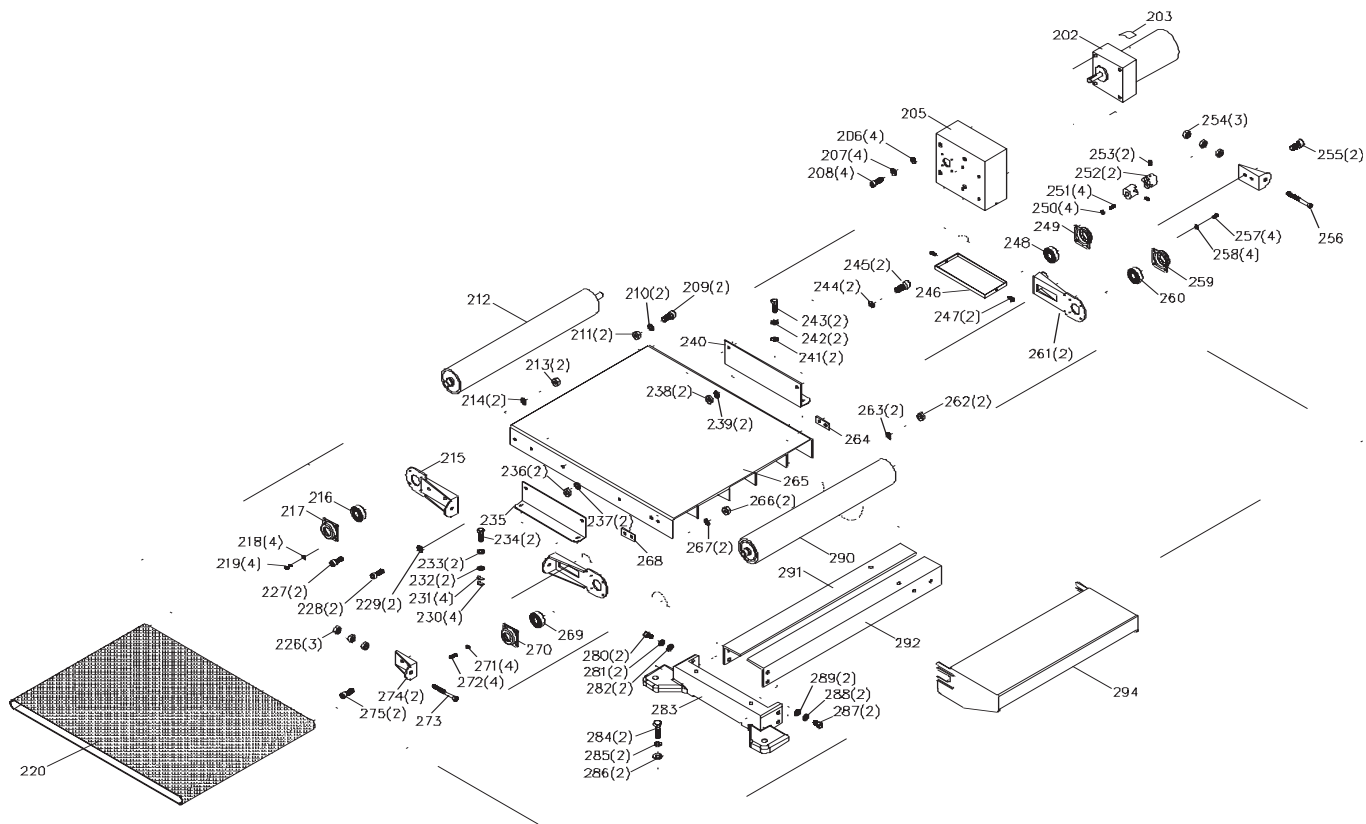

KEY NO.	PART NO.	DESCRIPTION	QTY.	KEY NO.	PART NO.	DESCRIPTION	QTY.
201	OR74118	REDUCTION MOTOR ASSY INC REF: 202,203	1	249	OR74131	BEARING CAP	1
202	OR74119	REDUCTION MOTOR	1	250	OR90145	WASHER LOCK M5	4
203	OR74120	REDUCTION MOTOR PLATE	1	251	OR90062	SCR PAN HD #10-24 x 1/4"	4
205	OR74121	GEAR BOX	1	252	OR74132	SHAFT COUPLER	2
206	OR90060	WASHER FLAT 1/4"	4	253	OR91762	SCR HEX SOC SET 1/4-20 X 1/4"	2
207	OR90070	WASHER LOCK 1/4"	4	254	OR90616	NUT HEX 5/16-18	3
208	OR91758	SCR HEX SOC HD M6 x 16mm	4	255	OR95081	SCR HEX SOC HD 1/4-20 x 3/4"	2
209	OR95081	SCR HEX SOC HD 1/4-20 x 3/4"	2	256	OR95082	SCR HEX SOC HD 5/16-18 x 4"	1
210	OR90060	WASHER FLAT 1/4"	2	257	OR90062	SCR ROUND HD #10-24 x 1/4"	4
211	OR94068	NUT NYLOK 1/4"	2	258	OR90145	WASHER LOCK M5	4
212	OR74122	REAR CONVEYOR ROLLER	1	259	OR74133	BEARING CAP	1
213	OR94068	NUT NYLOK 1/4"	2	260	OR95072	BEARING 6202	1
214	OR90060	WASHER FLAT 1/4"	2	261	OR74134	MICRO ADJUSTMENT PLATE	2
215	OR74123	POSITIONING PLATE	1	262	OR94068	NUT NYLOK 1/4"	2
216	OR95072	BEARING 6202	1	263	OR90060	WASHER FLAT 1/4"	2
217	OR74124	BEARING CAP	1	264	OR74136	PAD	1
218	OR90145	WASHER LOCK 5mm	4	265	OR74135	TABLE	1
219	OR90062	SCR PAN HD #10-24 x 1/4"	4	266	OR94068	NUT NYLOK 1/4"	2
220	OR74125	CONVEYOR BELT (406X1310)	1	267	OR90060	WASHER FLAT 1/4"	2
226	OR90060	NUT HEX 5/16-18	3	268	OR74136	PAD	1
227	OR95081	SCR HEX SOC HD 1/4-20 x 3/4"	2	269	OR95072	BEARING 6202	1
228	OR95081	SCR HEX SOC HD 1/4-20 x 3/4"	2	270	OR74137	BEARING CAP	1
229	OR90060	WASHER FLAT 1/4"	2	271	OR90145	WASHER LOCK M5	4
230	OR74126	TABLE SHIM	4	272	OR90062	SCR PAN HD #10-24 x 1/4"	4
231	OR74127	TABLE SPACER	4	273	OR95083	SCR HEX SOC HD 5/16-18 x 4"	1
232	OR90625	WASHER FLAT 5/16"	2	274	OR74138	MICRO ADJUSTMENT BLOCK	2
233	OR90615	WASHER LOCK 5/16"	2	275	OR95081	SCR HEX SOC HD 1/4-20 x 3/4"	2
234	OR90634	SCR HEX HD 5/16-18 X 1"	2	280	OR95054	SCR HEX SOC HD 5/16-18 x 1-1/4"	2
235	OR74128	TABLE BRACKET (LEFT)	1	281	OR90615	WASHER LOCK 5/16"	2
236	OR94068	NUT NYLOK 1/4"	2	282	OR90625	WASHER FLAT 5/16"	2
237	OR90060	WASHER FLAT 1/4"	2	283	OR74139	FRONT STAND	1
238	OR94068	NUT NYLOK 1/4"	2	284	OR90634	SCR HEX HD 5/16-18 X 1"	2
239	OR90060	WASHER FLAT 1/4"	2	285	OR90615	WASHER LOCK 5/16"	2
240	OR74129	TABLE BRACKET (RIGHT)	1	286	OR90625	WASHER FLAT 5/16"	2
241	OR90625	WASHER FLAT 5/16"	2	287	OR95054	SCR HEX SOC HD 5/16-18 x 1-1/4"	2
242	OR90615	WASHER LOCK 5/16"	2	288	OR90615	WASHER LOCK 5/16"	2
243	OR90634	SCR HEX HD 5/16-18 X 1"	2	289	OR90625	WASHER FLAT 5/16"	2
244	OR90060	WASHER FLAT 1/4"	2	290	OR74140	FRONT CONVEYOR ROLLER	1
245	OR95081	SCR HEX SOC HD 1/4-20 x 3/4"	2	291	OR74141	ROLLER BRACKET (LEFT)	1
246	OR74130	BOTTOM COVER	1	292	OR74142	ROLLER BRACKET (RIGHT)	1
247	OR90062	SCR PAN HD #10-24 x 1/4"	2	294	OR74143	FRONT EXTENSION TABLE	1
248	OR95072	BEARING 6202	1				

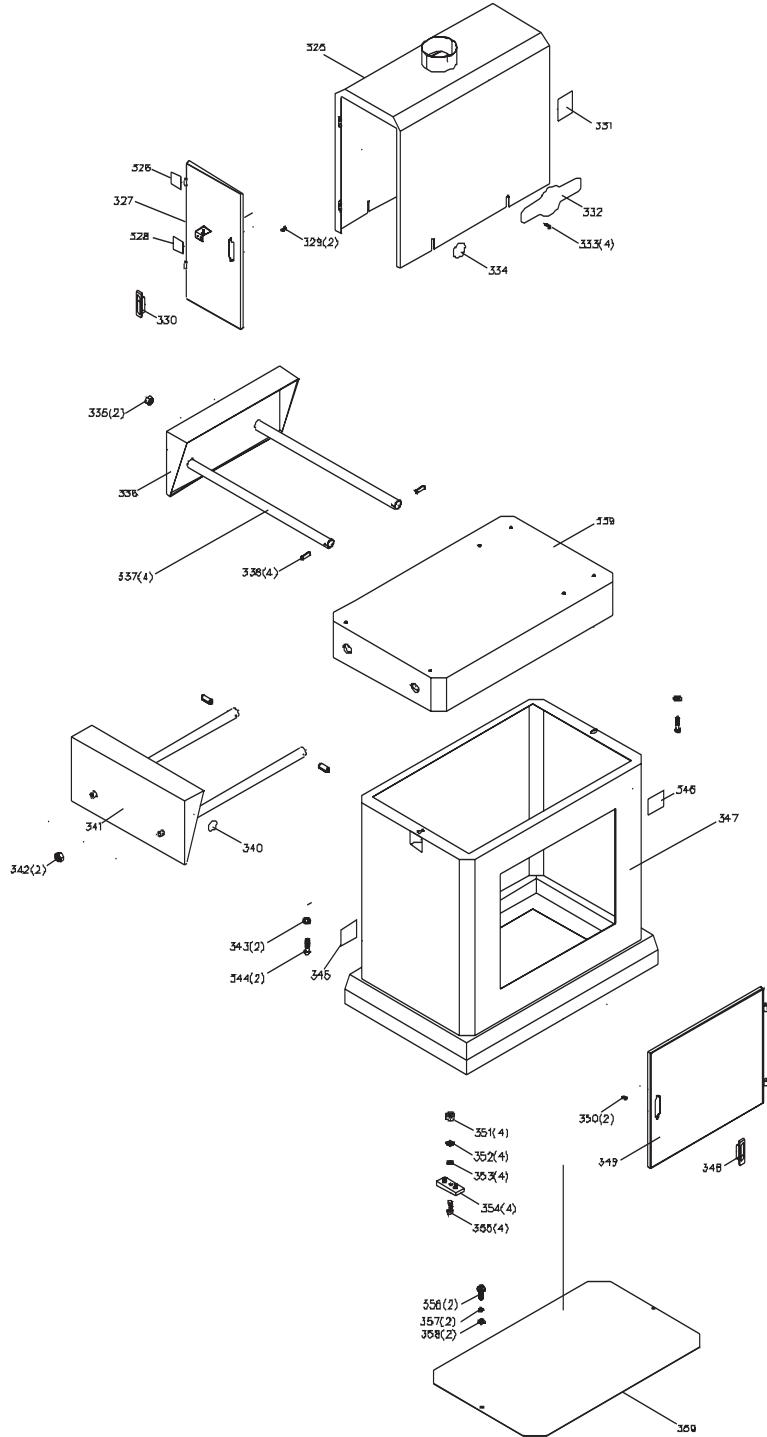
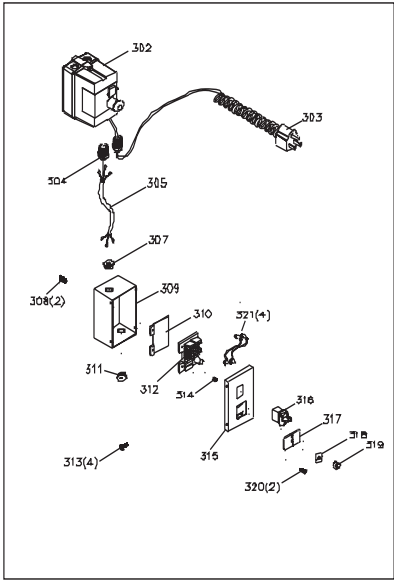

KEY NO.	PART NO.	DESCRIPTION	QTY.	KEY NO.	PART NO.	DESCRIPTION	QTY.
301	OR74144	SWITCH ASSY INC REF: 302 THRU 321	1	335	OR95085	NUT NYLOK 1/2-12	2
302	OR74145	MAGNETIC SWITCH	1	336	OR74166	EXTENSION TABEL (REAR)	1
303	OR74146	POWER CORD	1	337	OR74167	EXTENSION ROD	4
304	OR74147	STRAIN RELIEF	2	338	OR95086	PIN M3x12mm	4
305	OR74148	CORD	1	339	OR74168	BASE	1
307	OR74149	STRAIN RELIEF	1	340	OR74169	CAUTION LABEL	1
308	OR95084	SCR ROUND HD #10-24 x 1"	2	341	OR74170	EXTENSION TABEL (SIDE)	1
309	OR74150	SWITCH BOX	1	342	OR95085	NUT HEX 1/2-12	2
310	OR74151	PC BOARD PLATE	1	343	OR90625	WASHER FLAT 5/16"	2
311	OR74152	STRAIN RELIEF	1	344	OR95087	SCR HEX HD 5/16-18 x 1-1/4"	2
312	OR74153	PC BOARD	1	345	OR74171	SPEC PLATE	1
313	OR90062	SCR PAN HD #10-24 x 1/4"	4	346	OR74172	WARNING LABEL	1
314	OR90374	NUT HEX #10-24	2	347	OR74173	CABINET	1
315	OR74154	SWITCH BOX FRONT COVER	1	348	OR74174	LATCH	1
316	OR74155	SWITCH	1	349	OR74175	CABINET DOOR	1
317	OR74156	INSULATION BOARD	1	350	OR90135	SCR PAN HD M4 x 6mm	2
318	OR74157	LABEL	1	351	OR90616	NUT HEX 5/16-18	4
319	OR74158	KNOB	1	352	OR90625	WASHER FLAT 5/16"	4
320	OR93987	SCR FLAT HD M5 x 10mm	2	353	OR90615	WASHER LOCK 5/16"	4
321	OR74201	TERMINAL WIRE	4	354	OR74176	RUBBER FEET	4
325	OR74159	DUST HOOD	1	355	OR95088	SCR ROUND HD 5/16 x 3/4"	4
326	OR74160	LABEL	1	356	OR90135	SCR ROUND HD M5 x 12mm	2
327	OR74161	DOOR	1	357	OR90145	WASHER LOCK M5	2
328	OR74162	WARNING LABEL	1	358	OR90462	WASHER FLAT M5	2
329	OR90135	SCR PAN HD M4 x 6mm	2	359	OR74178	CABINET BOARD	1
330	OR74163	LATCH	1	500	OR93975	WRENCH OPEN END 12/14mm (Not Shown)	1
331	OR74164	WARNING LABEL	1	501	OR91729	HEX WRENCH 6mm (Not Shown)	1
332	OR70484	STEEL CITY LOGO	1	502	OR74178	MANUAL ENGLISH (NOT SHOWN)	1
333	OR93823	RIVET	4	503	OR74179	MANUAL SPANISH (NOT SHOWN)	1
334	OR74167	CAUTION LABEL	1	504	OR74180	MANUAL FRENCH (NOT SHOWN)	1

◆ NOTES ◆



STEEL CITY TOOL WORKS

www.steelcitytoolworks.com

1-877-SC4-TOOL
(1-877-724-8665)

5 Year Warranty

